

ProGauge

Installation

ProGauge MagLink LX Plus® Console

M2050-PLUS
Rev. 06 April 2026



ProGauge MagLink LX Plus® Console

DFS *Worldwide Brands*





ProGauge is a part of Dover Fueling Solutions.

Contact

DOVER FUELING SOLUTIONS ITALIA SRL

Via Natta 6

20823 Lentate Sul Seveso

MB, Italy

Tel. +39 0362 1581465

Fax +39 0362 1581464

Copyright Information

©2026 Dover Fueling Solutions. All rights reserved. DOVER, the DOVER D Design, DOVER FUELING SOLUTIONS, and other trademarks referenced herein are trademarks of Delaware Capital Formation, Inc./Dover Corporation, Dover Fueling Solutions UK Ltd. and their affiliated entities.

Security Best Practices

To prevent unauthorized access or unwanted intrusions into your system, DFS Information Technology strongly recommends that you obey the Security Best Practices that follow:

- Change the default password **immediately** to enhance security. Default passwords are often easy to guess or widely known, making devices vulnerable to unauthorized access.
- Limit access to the system. Access should only be granted on a need-to-know basis.
- Secure all control systems by minimizing their exposure and ensuring that they are not accessible from the Internet. This is important to prevent unauthorized access.
- Identify the control system network and relocate devices behind firewalls.
- Isolate the system from the business network to enhance security measures.
- Maximize isolation of the different networks (segmentation) by firewalls, routers, and VPN solutions to largely exclude attack paths to the Industrial Control System network.
- When remote access is required, use secure methods, such as Virtual Private Networks (VPNs) or known secure remote access management tools. Use the latest version of the tools and implement the updates as recommended.

Notices



IMPORTANT: Before you use this manual, make sure you have the most recent revision. Look at the revision of this document to make sure it agrees with the most current revision found in the FMS Technical Library. Download the latest revision if necessary.



IMPORTANT: If you have an installation in an area that has possible Internet connectivity issues, it is recommended to either print or download these manuals to a mobile device (mobile phone or tablet) before you go to the installation site.



READ CAREFULLY: Dover Fueling Solutions cannot be held responsible for installations, configurations or use of its products that does not comply with the most recent documentation available.



NOTE: It will be necessary to have Single Sign-On (SSO) credentials to get access to manuals, instructions, software updates and other important assets. Speak with your FMS sales representative or contact FMS Customer Service at 1-888-679-3835 (1-888-OPW-FUEL) for information. Once you have been approved for SSO credentials go to the [FMS Technical Library](#) to find the most recent revisions of all manuals and instructions.



NOTE: All references to other manuals and instructions in this manual can be found in the FMS Technical Library. Make sure you have the most recent revision.

Related Manuals

[M2050 LX 4 Installation Manual](#)

[M2050-PLUS LX Plus Installation Manual](#)

[M2051 LX 4-LX Plus-LX Ultimate Configuration Manual](#)

[M2052 LX 4-LX Plus-LX Ultimate User Manual](#)

[M2054-QS LX Consoles Quick Start](#)

[FMM2058-PLS LX Plus Wiring Diagram](#)

[FMM2058-PG LX Plus Wiring With ProGauge](#)

[FMM2060 LX Ultimate Installation Manual](#)

Installation

ProGauge MagLink LX Plus® Console

M2050-PLUS
Rev. 06 April 2026

Table of Contents

Notices	. 3
Related Manuals	. 4
1 Preface	. 11
2 General Warnings	. 12
3 Introduction	. 14
4 General Indications	. 16
5 Labeling and Type Designations	. 18
6 CAN/CSA C22.3 NO. 61010-1-12	. 19
7 Installation	. 21
7.1 Installation Warnings	. 21
7.2 Installation Location	. 22
7.3 Electrical Connection	. 23
7.4 Installation Procedure	. 24
8 Console Components	. 26
8.1 Rear Panel	. 26
8.2 Front Panel	. 27
8.3 Micro SD Card	. 28
8.4 Battery Safety and Replacement	. 29
8.5 Compatible Devices	. 30
8.6 Device Connections to the ISB-1W Internal I.S. Barrier	. 31
8.7 Auxiliary Board LEDs	. 32

9	Probe Installation Preparation	33
9.1	Probe Placement	34
9.2	Product Offset Calculation	35
9.3	Riser, Manhole and Junction Box Installation	36
9.3.1	Riser Assembly	36
9.3.2	Manhole and Junction Box	37
9.4	Conduit Seal Fittings for Cables	39
9.5	Probe Installation in Underground Storage Tanks	42
10	924B Probe Installation	43
10.1	Probe Floats	43
10.2	Model 924B Probe Specifications	44
11	Dover Magnetostrictive Probe (DMP)	45
11.1	DMP-IS Technical Characteristics	45
11.2	DMP Probe Installation	47
11.3	Spacer Assembly (6-3/4 RA SS) and Adjustment	50
11.4	DMP Probe Cable Wiring to I.S. Barrier	52
11.4.1	DMP wiring to Belden 88770	52
11.4.2	DMP wiring to Belden 88760	53
12	Density Measurement Float (DMF)	54
12.1	DMF Installation	55
12.2	Tank Thresholds	56
13	DMP Density Measurement Float	57
13.1	DFS Density Measurement Float Installation	58
13.2	Tank Thresholds	59
13.3	Calibration on First Installation	60
14	Sensor Support	61
14.1	IntelliSense Technology	61
14.2	Mixed Multi-Drop Installation	61
14.3	Smart Sensors	62
14.4	Interstitial Level Sensor	63
14.4.1	Smart Sensor Equipped with Intellisense™ Technology	63
14.4.2	Description	63
14.4.3	Installation	64
14.4.4	Connections	65
14.4.5	Typical Installation Drawings	66
14.4.6	Controller Setup	67
14.4.7	Float Sensor Test	68
14.5	Single Level Sump Sensor-Float Switch	69
14.5.1	Smart Sensor Equipped with Intellisense™ Technology	69
14.5.2	Description	69

14.5.3	Installation	70
14.5.4	Connections	71
14.5.5	Typical Installation Drawing	72
14.5.6	Controller Setup	72
14.5.7	Float Sensor Test	72
14.6	Dual Float Non-Discriminating Sensors	73
14.6.1	Smart Sensor Equipped with Intellisense™ Technology	73
14.6.2	Description	73
14.6.3	Installation	74
14.6.4	Connections	75
14.6.5	Typical Installation Drawing	75
14.6.6	Controller Setup	75
14.6.7	Float Sensor Test	76
14.7	Discriminating Dispenser Sump/STP Sump Sensor	77
14.7.1	Smart Sensor Equipped with Intellisense™ Technology	77
14.7.2	Description	77
14.7.3	Installation	79
14.7.4	Connections	80
14.7.5	Typical Installation Drawing	80
14.7.6	Controller Setup	80
14.7.7	Float Sensor Test	81
14.7.8	Hydrocarbon Sensor - Functional Test and Remove Contamination	81
14.8	Dual Float Brine Sensors	83
14.8.1	Smart Sensor Equipped with Intellisense™ Technology	83
14.8.2	Description	83
14.8.3	Installation	85
14.8.4	Connections	85
14.8.5	Typical Installation Drawing	86
14.8.6	Controller Setup	86
14.8.7	Float Sensor Test	87
14.9	Interstitial Hydrocarbon Liquid Sensor with Water Indicator	88
14.9.1	Smart Sensor Equipped with Intellisense™ Technology	88
14.9.2	Description	88
14.9.3	Installation	89
14.9.4	Connections	89
14.9.5	Typical Installation Drawing	90
14.9.6	Controller Setup	90
14.9.7	Interstitial Hydrocarbon Liquid Sensor with Water Indicator - Functional Test and Remove Contamination	91
14.10	Hydrocarbon Liquid Sensor with Water Indicator	93
14.10.1	Smart Sensor Equipped with Intellisense™ Technology	93
14.10.2	Description	93
14.10.3	Installation	94
14.10.4	Connections	94
14.10.5	Typical Installation Drawing	95
14.10.6	Controller Setup	95

14.10.7	Hydrocarbon Liquid/Water Sensor - Functional Test and Remove Contamination	96
14.11	Hydrocarbon Vapor Sensor	99
14.11.1	Smart Sensor Equipped with Intellisense™ Technology	99
14.11.2	Description	99
14.11.3	Installation	100
14.11.4	Connections	101
14.11.5	Typical Installation Drawing	102
14.11.6	Controller Setup	102
14.11.7	Test the Hydrocarbon Vapor Sensor	103
14.11.8	Clean the Hydrocarbon Vapor Sensor	103
14.12	Discriminating Interstitial Sensor (Optical)	104
14.12.1	Smart Sensor Equipped with Intellisense™ Technology	104
14.12.2	Description	104
14.12.3	Installation	105
14.12.4	Connections	106
14.12.5	Typical Installation Drawing	107
14.12.6	Controller Setup	107
14.12.7	Test the Optical Sensor	108
15	Probe and Sensor Wiring	109
16	PLLD (Pressurized Line Leak Detection) Pressure Sensor Device Installation	110
16.1	PLLD Specifications	110
16.2	PLLD Installation	111
17	PLLD-DAS	115
17.1	General Warnings	115
17.2	General Indications	116
17.3	Installation	117
17.3.1	Preliminary Warnings	117
17.3.2	Installation Location - Attach the Device to a Wall	118
17.3.3	Electrical Connections	119
17.3.4	Module Components and Internal Wiring	120
	Exploded View of Components	121
17.3.5	Power and RS485 Connection within the Enclosure	122
17.3.6	PLLD Sensor Connection to the I.S. Barrier	123
	New style PLLD sensor with cable pigtail	123
	Older style PLLD sensor with angular connection	124
17.3.7	LED Operation	125
17.3.8	ID Addresses/DIP Switches	126
17.4	Maintenance	127
17.5	Safety Instructions - Control Drawing	127
18	OM4 Output Module (Optional)	128

18.1	Safety Precautions	129
18.2	Codes	129
18.3	Hazardous Area Definition	129
18.4	OM4 Technical Specifications	130
18.5	Product Certifications	130
18.6	OM4 Installation	130
18.7	OM4 Connections	131
18.8	Petro-Net Address Jumper Settings	132
19	Tank Alert (Overfill Alarm) (Optional)	133
19.1	Safety Information	133
19.2	Tank Alert Specifications	134
19.3	Tank Alert Installation	134
19.4	Tank Alert Wiring	135
20	M00-20-8319 VSmart Module (Optional)	136
20.1	VSmart Specifications	137
20.2	VSmart Module Installation	138
20.2.1	Probe & Sensor Conduits	139
20.2.2	Circuit Breaker Conduits	139
20.3	External VSmart Module Wiring	140
20.3.1	Device Wiring to Barriers	141
	Device Wiring to Belden 88770	141
	Device Wiring to Belden 88760 (or equivalent)	145
20.3.2	Petro-Net Address	148
20.4	VSmart Capacities	149
21	Close and Startup	150
22	Connections to Management Systems (POS-FCC)	151
22.1	TOKHEIM FUEL POS / DIALOG	151
22.2	Wayne Fusion	152
22.3	GILBARCO Fuel Management System	153
23	Maintenance and Technical Support	154
23.1	Maintenance	154
23.2	Technical Support	154
Appendix A	NWGLDE Certifications	155
Appendix B	Console Dimensions	157
Appendix C	Descriptive System Document	158
Appendix D	LX Plus Field Wiring Diagram	161

Appendix E LX Plus Field Wiring with ProGauge 162

Revisions - M2050-PLUS 163

1 Preface

Dover Fueling Solutions Italia S.r.l. has made every effort possible to see that this document is complete, accurate and updated. With every revision of the console, the related information is added to the document. Dover Fueling Solutions Italia S.r.l. reserves the right to make unannounced improvements and/or changes in the product and/or associated programs. Dover Fueling Solutions Italia S.r.l. is not liable for damages of any kind, including those resulting in the document, including typographical errors.

Making copies, citing quotes or other reproductions of all or part of this document is permitted only after written consent of Dover Fueling Solutions Italia S.r.l.

Patents protect trademark or name.

Copyright 2026© Dover Fueling Solutions Italia S.r.l. – All rights reserved.

2 General Warnings

Carefully read the instructions in this manual before you do the installation procedures.

Only approved persons are permitted to install this equipment and configure the console.

The manufacturer is not responsible for operations that are not included in this manual.

The manufacturer is not liable in regards to competent bodies for changes to the equipment and software that are not approved.

In case of failure or defect, refer directly to an authorized service provider or manufacturer.

The manufacturer is not liable for injury and/or damage to persons and/or property and/or pets caused by the failure to obey safety instructions.

All approved personnel must know all safety requirements in this manual, the configuration manual and the user manual.

Refer directly to an approved service provider or manufacturer for questions about the operation of the equipment.



IMPORTANT: You must read and obey all safety instructions in this manual before you use this equipment.



WARNING!

Incorrect use of this equipment that does not agree with the instructions in this manual can cause a risk to safety.



WARNING!

A minimum insulation thickness of 0.25 mm is necessary for all internal wiring of different intrinsically safe circuits.



A grounding conductor must be connected between the I.S. ground terminals of the Intrinsic safety barrier in the console and the power distribution panel. This connection must have a cross-sectional area of at least 4 mm² for the added earth connection.

	WARNING	ADVERTISSEMENT !
	Substitution of components can decrease intrinsic safety.	La substitution des composants peut compromettre la sécurité intrinsèque.



READ CAREFULLY: *The control drawing shown in ILL. 14 shall be provided with all devices.*



IMPORTANT: *If a replacement power supply cable is necessary, use an applicable, approved ELBZ/7 type power cord. Do not use another type of power cable.*

3 Introduction

This manual was prepared in accordance with IEC 82079-1 standards. "Preparation of instructions for use - Structuring, content and presentation - Part 1: General principles and detailed requirements and according to the ATEX Directive 2014/34/EU concerning equipment and protective systems intended for use in potentially explosive atmospheres."



This manual gives all necessary information about the installation of the ProGauge MagLink LX 4®/ LX Plus® console.

IMPORTANT: This manual must be used together with the related product manuals:



- M2051 MagLink LX 4/LX Plus Configuration Manual
- M2052 MagLink LX 4/LX Plus User Manual

You must install the console as shown in this manual, configure the console as instructed in the Configuration Manual, and use the console in the field as shown in the User Manual.

 WARNING!	
	<p>This device must not be discarded with household waste. This device is labeled in accordance with European Directive 2012/19/UE concerning used electrical and electronic appliances (waste electrical and electronic equipment – WEEE)</p> <p>This guideline gives the methods for the return and recycling of used electronic devices as applicable throughout the EU. To return your used device, use the return and collection systems available to you.</p>
	<p>The battery used in this device may present a risk of fire or chemical burn if mistreated. Do not disassemble, heat above 50°C or incinerate.</p>

The table that follows lists reference data of the manufacturer:

Data	Description
Name	Dover Fueling Solutions S.r.l.
Address	Via Natta 6 20823 Lentate Sul Seveso, (MB) Italy
Telephone	+39 0362 1581465
Fax	+39 0362 1581464
Website	www.doverfuelingsolutions.com



IMPORTANT: *The units of measurement contained in this manual refer to a specified selection by the user. Refer to the M2051 MagLink LX 4/LX Plus Configuration Manual for more information on how to set units of measure.*

4 General Indications

The MagLink LX Plus console is shipped in a cardboard box (L 450 x H 300 x D 200 [mm]) and includes the components as follows:

- MagLink LX Plus console
- Quality control certification checklist
- User manual, installation manual and web configuration manual

Weight of the console with its carton: 2 kg.

The table below shows the primary technical characteristics of the console:

Element	Characteristic
Display	Display TFT 7 inch Dimensions 155 x 88 [mm]
Console	Dimensions <ul style="list-style-type: none"> • Width 267 mm • Height with cable: 215 mm • Depth 80 mm

The illustration below shows the ports and connections on the bottom of the console:

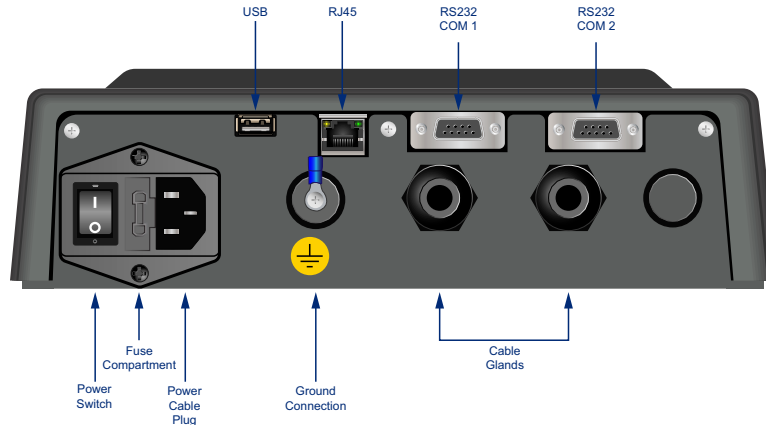

Make sure that the power cable is correctly installed. Put the Power Switch to the on ("I") position to supply power to the console.

Put the Power Switch in the off ("O") position to remove power from the console.

**DANGER!**

The console can contain electrical power after it has been shut down. To prevent electrical shock do not open the console to do service for a minimum of two (2) minutes.



IMPORTANT: Wait a minimum of two (2) minutes before you supply power to the console again after it has been put in the Off position. This will give the console time to fully shut down.

Element	Description
USB	For USB printer connection. It can also be used for firmware updates and back-up of the console (Refer to the M2052 MagLink LX 4/LX Plus User Manual)
RJ45	For console configuration, and local network connections (Refer to the M2051 MagLink LX 4/LX Plus Configuration Manual)
RS232 Com 1	Serial port for connection to management systems (FCC/POS/DCD)
RS232 Com 2	Serial port for connection to management systems (FCC/POS/DCD)
Ground connection	Ground connection of the internal Intrinsically Safe barrier. Use a dedicated 4.0 mm ² copper cable to connect to the main ground lug in the electrical panel of the station. This will prevent high voltages sent to the Intrinsically Safe wiring side if there is an electrical fault in the power side.

5 Labeling and Type Designations

The table below shows the labels attached to the LX Plus console:

Label	Description																		
	<p>Product label attached to the side of the console.</p>																		
<p>Associated Device, Provides intrinsically safe circuit extensions for use in Hazardous Locations when connected per Control Drawing No. 210909.</p> <p>WARNING - Substitution of components may impair intrinsic safety AVERTISSEMENT- La substitution des composants peut compromettre la sécurité intrinsèque</p>	<p>I.S. Warning label attached next to the Product label.</p>																		
<p>Replace battery with Panasonic part Number ML621 Only Use another battery may present a risk of fire or explosion. See owner manual for safety instruction</p>	<p>Label attached to the aluminium plate near the RTC battery that shows replacement information.</p>																		
<p>Intrinsically safe circuits wiring</p>	<p>Label attached under the cable gland related to safety circuit (only if the color of the cable gland is different than blue).</p>																		
<table border="1" data-bbox="315 1690 678 1745"> <thead> <tr> <th>Parameter</th> <th>U_L/U_C</th> <th>I_L/I_C</th> <th>P₀</th> <th>L₀/L_C</th> <th>C₀/C_C</th> </tr> </thead> <tbody> <tr> <td>Group D</td> <td>14.85 V</td> <td>305 mA</td> <td>974 mW</td> <td>1.52 mH</td> <td>3.0 uF</td> </tr> <tr> <td></td> <td></td> <td></td> <td></td> <td>600 uH</td> <td>3.0 uF</td> </tr> </tbody> </table>	Parameter	U _L /U _C	I _L /I _C	P ₀	L ₀ /L _C	C ₀ /C _C	Group D	14.85 V	305 mA	974 mW	1.52 mH	3.0 uF					600 uH	3.0 uF	<p>Label attached to the ISB-1W, internally.</p>
Parameter	U _L /U _C	I _L /I _C	P ₀	L ₀ /L _C	C ₀ /C _C														
Group D	14.85 V	305 mA	974 mW	1.52 mH	3.0 uF														
				600 uH	3.0 uF														

6 CAN/CSA C22.3 NO. 61010-1-12

Clause Ref	STATEMENTS/INFORMATION REQUIRED IN MANUAL	Yes	No
5.4.1h	Instructions for lifting and carrying		X
5.4.2 e	Ingress Protection (IP) rating and any mounting arrangements required	X	
5.4.2 f	Details on an impact rating with an IK code (if less than 5J)		X
5.4.3 a	Assembly, location and mounting requirements	X	
5.4.3 b	Instructions for protective earthing	X	
5.4.3 c	Connections to the supply	X	
5.4.3 d	For permanently connected equipment; supply wiring requirements and requirements for any external switch or circuit-breaker and external overcurrent protection devices and a recommendation that the switch or circuit-breaker be near the equipment		X
5.4.3 e	Ventilation requirements		X
5.4.3 f	Requirements and safety characteristics for special external services		X
5.4.4 b	Instructions not to position the equipment so that it is difficult to operate the disconnecting device		X
5.4.4 c	Instructions for interconnection to accessories and other equipment, including indication of suitable accessories, detachable parts and any special materials	X	
5.4.4d	Specifications of limits for intermittent operation		X
5.4.4 f	Instructions for replacement of consumable materials	X	
5.4.4 g	Instructions for cleaning and decontamination		X
5.4.4 h	A statement listing potentially poisonous or injurious substances that can be liberated from the equipment, and possible quantities		X
5.4.4 i	Detailed instructions about risk reduction procedures relating to flammable liquids		X
5.4.4 j	Details of methods of reducing the risks of burns from surfaces		X
5.4.4	There shall be a statement in the instruction which states that if the equipment is used in a manner not specified by the manufacturer, the protection provided by the equipment may be impaired	X	
5.4.5	Instruction against replacing detachable mains supply cords by inadequately rated cords	X	
5.4.5	The specific replaceable battery type shall be stated	X	
5.4.5	Any parts which are required to be examined or supplied only by the manufacturer or his agent are specified		X
5.4.5	The rating and characteristics of replaceable fuses shall be stated	X	

Clause Ref	STATEMENTS/INFORMATION REQUIRED IN MANUAL	Yes	No
5.4.5	Product-specific risks that may affect the service personnel, protective measures for these risks and verification of the safe state of the equipment after repair.		X
5.4.6	Aspects resulting from integration into systems or effects resulting from special ambient or application conditions shall be described in the documentation		X

7 Installation

7.1 Installation Warnings

	CAUTION!
The MAGLINK LX-PLUS console is not explosion-proof.	

	CAUTION!
Explosions or fires can cause damage or even death!	

	CAUTION!
Flammable vapours when mixed with air can cause an explosion. Dangerous areas can occur from the presence of gases or vapours.	

	CAUTION!
Do not install the console in a hazardous area.	

	CAUTION!
Only use fuses file JDYX2/8.E10480. Series 218 (Model code 0218001) Littlefuse INC. Rated 250 V - 1 A for input power.	

	CAUTION!
Failure to connect the Intrinsically Safe Ground connection console to the earth system of the station will compromise the intrinsic safety of the device and may result to high voltage to be sent to the hazardous area thus leading to a potential explosion or fire.	

7.2 Installation Location

Select a location for the console installation where weather cannot cause negative effects or damage to the electrical circuits (high and low temperatures, high humidity, direct sunlight etc.).

	NOTICE!
Install the console in a place that is protected from moisture, direct sun, and water splashes. The console should be installed indoors in a climate-controlled room.	

	CAUTION!
The console must be installed in a safe area.	

7.3 Electrical Connection

To make a connection to 110-220 VAC:

- De-energize all power switches at the main electrical panel.
- Make sure to use the applicable connections to connect the console to the electrical panel.
- A Power Supply Cord is not supplied: Use an applicable, approved ELBZ/7 type power cord.
- Make sure the power plug is connected to the ground and protected against short circuits and power surges.
- Make sure to connect the I.S. ground to the site's earth system. Use a dedicated 4.0 mm² copper cable (see the illustration below).



- The power cord must be easy to identify and must have easy access so it can be used to remove power.



WARNING!

There is high voltage within the console



IMPORTANT: *The electrical connection procedure must be done by approved personnel only!*

7.4 Installation Procedure

1. Remove the three (3) cover screws as shown in the illustration below.

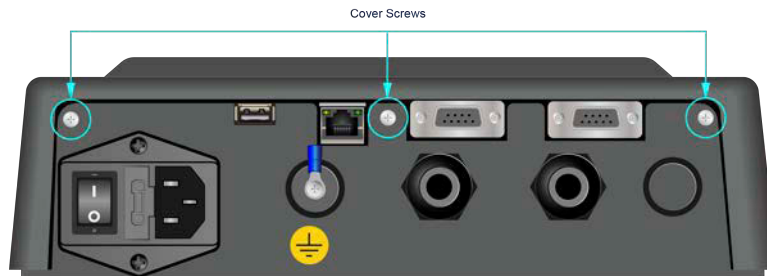

2. Lift the cover carefully and disconnect the ribbon cable from the rear panel of the console as shown in the illustration below. Put the cover and screws in a temporary safe location where they can be found later and where the components cannot be damaged.

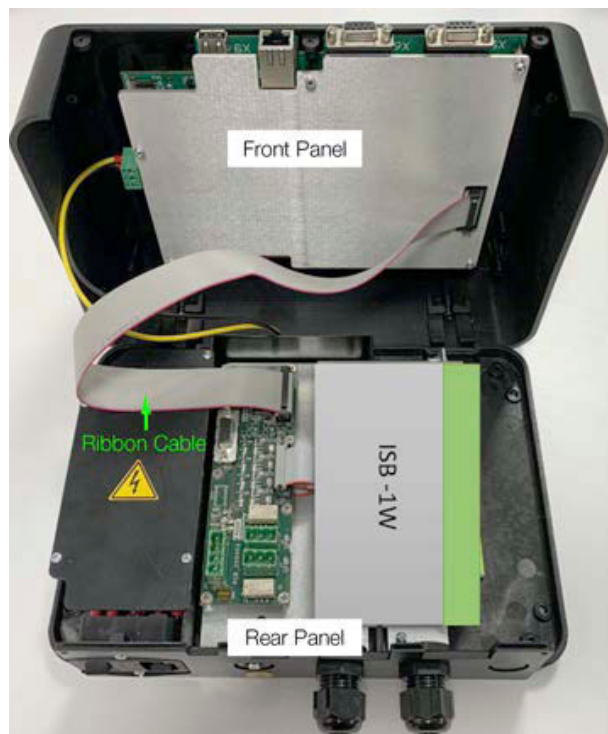

3. Attach the rear panel to a wall.

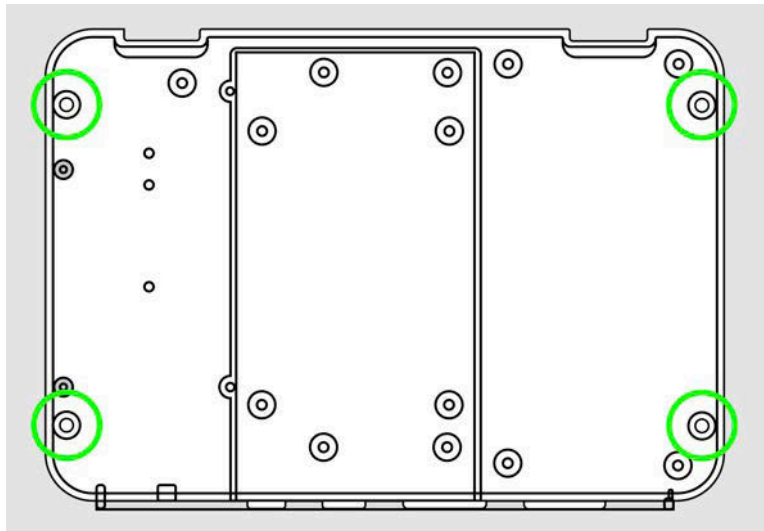

- a. Select a location to attach the console to an indoor wall where it can be easily seen. Make sure to keep sufficient access to the connection ports on the bottom of the console.
- b. Hold the unit against the wall where it will be attached. There are four (4) mounting screw holes in the unit (see the illustration above for the locations of the holes).
- c. Use a pen to identify the screw hole locations on the wall.
- d. Drill the holes at the screw hole location marks.
- e. Tap the holes for an applicable screw size or put screw anchors in the hole.
NOTE: *It is recommended to use size 6 Fischer wall anchors.*
- f. Attach the unit to the wall with the applicable screws.

8 Console Components

8.1 Rear Panel



- 1. Power supply (PSU) protection panel.
- 2. Auxiliary board with 2 output relays NO and RS485 / RS232 communication ports.
- 3. ISB-1W 4-channel 12V Intrinsically Safe barrier

Relay Specifications	
Rated Load	0.5 A at 125 VAC; 2 A at 30VDC
Rated Carry Current	2 A
Max. Switching Voltage	250 VAC, 220 VDC
Max Switching Current	2 A

8.2 Front Panel



The front panel contains the main processing board with the touch screen display and the communication ports.

1. Power-IN
 - Yellow (+12V): Terminal 1
 - Black (-0V): Terminal 2
 - Not used: Terminal 3
2. Ribbon cable that connects the back panel with the front panel.

8.3 Micro SD Card



The illustration above shows the location of the Micro SD Card. The SD Card contains the operating system, firmware, configuration and a history of the console.



IMPORTANT: Do not remove the micro SD card while the console is in operation. The console cannot function without the SD card in place.

The Real-Time-Clock of the processing unit is supported by a battery that is located on the main electronic board of the unit.

8.4 Battery Safety and Replacement

Replace Battery With Panasonic Part No. ML621 Only. Use Of Another Battery May Present A risk Of Fire Or Explosion. See Owner's Manual For Safety Instructions.

**DANGER!**

The coin cell battery may explode if mistreated. Do not recharge, disassemble or dispose of in fire. Replace coin cell battery with Replace Battery With Panasonic Part No. ML621 ONLY. Use of another battery may present a risk of fire or explosion.

To avoid possible explosion or fire, do not replace the lithium battery with a type that is not compatible.

 Battery can explode if mistreated. Do not recharge, disassemble or dispose of in fire.

 The battery used in this device may present a risk of fire or chemical burn if mistreated. Do not disassemble, heat above 100°C or incinerate.

 Dispose of used battery promptly. Keep away from children. Do not disassemble and do not dispose of in fire.

The console can remain energized via the backup battery, even though the line power has been removed.

The inside of the console contains high-voltage circuitry; ONLY certified technicians should be permitted access to the console.

An external disconnect device must be installed for any permanently connected equipment!

An electrical outlet must be installed near any equipment requiring access through a plug connection!

The console has one (1) lithium battery. When the battery can no longer hold sufficient electrical power it must be replaced.



IMPORTANT: *Replace the battery with a recommended replacement ONLY. Use of a different battery can cause a risk of fire or explosion.*

A used battery must be removed from the console. Used batteries must be moved to a battery-recycling center for approved disposal.

8.5 Compatible Devices

The devices shown below can be connected to the ISB-1W I.S barrier that is contained in the console:

- 924B probes
- DMP 1-wire probes
- Smart sensors

8.6 Device Connections to the ISB-1W Internal I.S. Barrier

The ISB-1W 12V I.S (Intrinsically Safe) barrier has four channels where probes and sensor can connect.



There are no serviceable components within the barrier. If a channel become defective, it cannot be used. The remaining channels can continue to be used.

The ISB-1W I.S barrier is powered by the 12V DC supply of the console. It supplies 12V DC to the devices in the field.

The devices can be multi-dropped to each I.S channel (multiple probes and sensors can be connected to the same I.S channel on the same field cable).

There is a maximum limit of three (3) probes or 12 sensors that can be connected to a barrier channel.

The maximum number of devices that can connect to the ISB-1W barrier is 12 probes or 48 smart sensors.

A range of different device connections can be made. Refer to the illustration below for possible combinations.

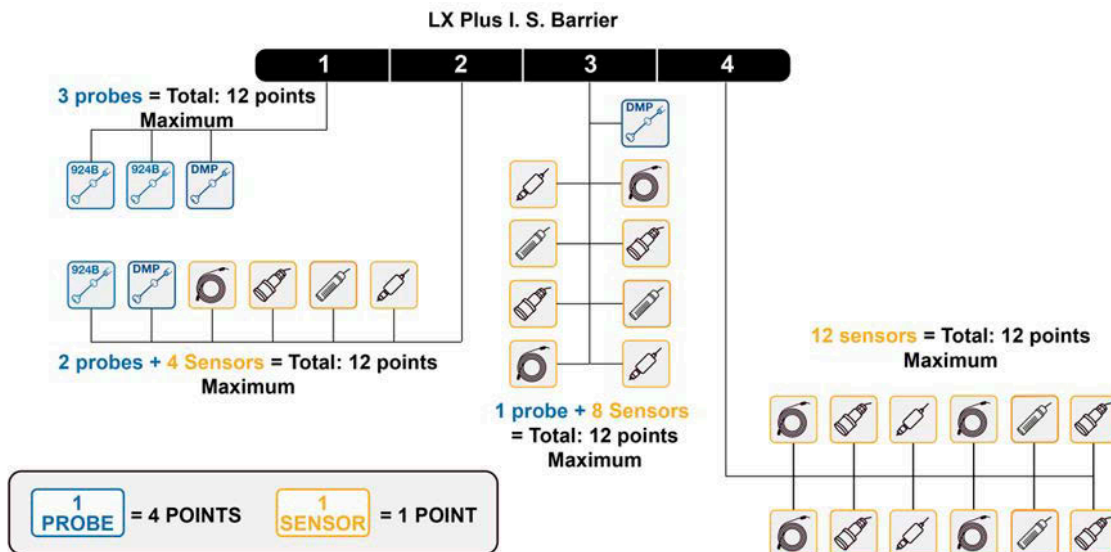

8.7 Auxiliary Board LEDs

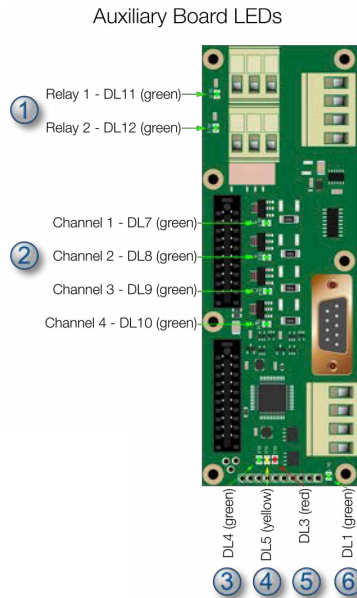

1. DL 11 (relay 1) / DL12 (relay 2), will come on (green) when the relay is energized.
2. DL 7 (Channel 1) green, DL 8 (Channel 2) green, DL 9 (Channel 3) green, DL 10 (Channel 4) green

When device detection occurs, these four (4) LED lights will come on in sequence. This shows that power is applied to each of the channels on the barrier. When devices are sensed on a channel its LED will remain on. When a device is not sensed on a channel, its LED will go off. Device detection occurs when power is applied to the console, the software is updated or device detection is started.

3. DL 4 (green): This LED will flash when the firmware on the auxiliary board operates. When the software is updated the light will first stay on and then it will flash.
4. DL 5 (yellow): This LED will flash when communication between the auxiliary board and the console mainboard is occurs. When there is no communication for more than 30 secs, the LED will stay on. During a software update the LED will go off.
5. DL 3 (red): This LED operates only during a software update. While information is saved the LED will flash. If a problem occurs when information is saved, the LED will stay on.
6. DL 1 (green) (power): This LED will come on when power is applied to the the auxiliary board.

9 Probe Installation Preparation

This section shows the procedures necessary for installation of tank probes that will be connected to your console.

Topics in this section include:

[Probe Installation Preparation](#) (p. 33)

[Product Offset Calculation](#) (p. 35)

[Riser, Manhole and Junction Box Installation](#) (p. 36)

[Conduit Seal Fittings for Cables](#) (p. 39)

[Probe Installation in Underground Storage Tanks](#) (p. 42)

9.1 Probe Placement

**CAUTION!**

Model 924B and DMP probes must be installed as shown in this section. If the installation cannot be done with the minimum or maximum dimensions specified, do not continue with the installation.

Model 924B and DMP probes are safe for Class 1, Div 1, Group D hazardous locations. This includes tanks containing regular, super, diesel and unleaded gasoline; antifreeze; kerosene; mineral spirits; oxinol, methanol and methanol blends; motor, torque and transmission oil; and alcohol. If you are not sure if a product is included in this class, speak to your product specialist or distributor.

The best location to install a probe is in the center of the tank (see the illustration below).

The probe must be installed (approximately) a minimum of three (3) feet (91 cm) from the tank fill-pipe. If the distance is less than this interval, the force of the product that goes into the tank can cause the water float to travel up the shaft of the probe. This can cause the controller to give an incorrect high-water alarm.

Adjust the drop-tube of the fill pipe so that the product flow is pointed away from the probe.

A Submersible Turbine Pump (STP) must be installed (approximately) a minimum of three (3) feet (91 cm) from the probe. If the distance is less than this interval, the force of the product that the pump pulls from the tank can cause incorrect indications of the water and product floats.

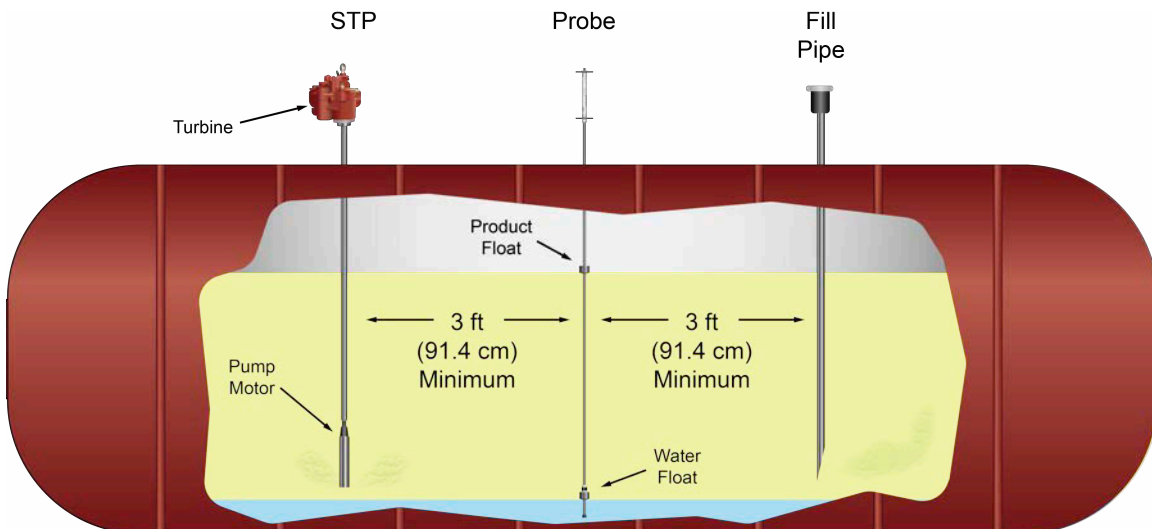

Figure 9-1 Probe Placement

9.2 Product Offset Calculation

It is possible to calculate product offset for a probe that is not installed in the center of a "pitched" tank. Pitch occurs when a tank is installed tilted along its horizontal axis. Some tanks are installed with one end lower than the other to let water and sediment collect at the low end, so that clear product can be pulled from the high end. Tank "settling" can also occur and can cause a tank a tank to become tilted. Use a dipstick to measure the level of product at two points of the tank. It is recommended that these measurements be taken at opposite ends of the tank (see the figure below).

The product depth at the lower end of the tank is value "A." The product depth at the higher end is value "B." The distance between the two measuring points is "C."

The formula for pitch is:

$$(A-B)/C$$

For example:

$$(46"-40")/120" = 6"/120" = 0.05"$$

To calculate the product offset, measure value "D," the distance of the probe from the center of the tank. The formula for product offset is "**D**" x **pitch**. For the example above: 36" x 0.05 = 1.8".

If the probe is located closer to the higher end of the tank, the product offset is positive. For the example above: 1.8".

If the probe is located closer to the lower end of the tank, the product offset is negative; for the example above: -1.8".

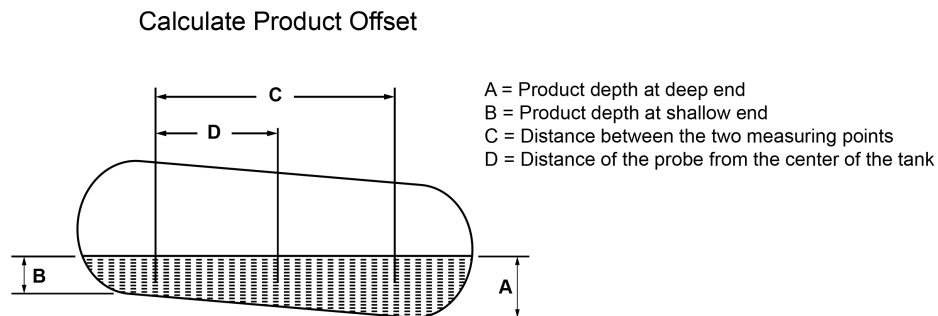





Figure 9-2 Product Offset

9.3 Riser, Manhole and Junction Box Installation

Install the components shown below after the probe installation location in the tank has been selected.

 **WARNING!**



To prevent explosion or fire, it is recommended to use non-sparking tools in an environment that could contain flammable hydrocarbon vapors. **DO NOT USE CORDED ELECTRIC OR BATTERY OPERATED POWER TOOLS.** Only use pneumatic or manual tools.

9.3.1 Riser Assembly

A four (4) inch diameter riser pipe must be installed on the tank opening where the probe will be installed. The riser pipe must be of sufficient length to hold the probe head, connector and an applicable length of cable.

An adapter collar and riser cap must be installed on the riser pipe to keep contamination out of the fuel tank. The riser must be tapped to accept the correct thread for the adapter collar and riser cap assembly.

 **NOTICE!**

Tap the applicable threads on the top of the riser before it is installed so that contamination does not enter the tank.

DFS recommends to use the OPW 62M Monitor Probe Cap & Adapter Kit (OPW- FMS P/N 30-0219 for 924B Probe installations [Accepts .069" - .178" diameter wire] and PN/ 30-0229 for DMP Probe installations [Accepts .170" - .470" diameter wire]). The illustration below shows the cap and adapter dimensions and thread specifications for reference.

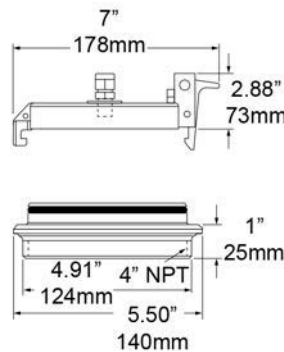

You can keep the cap off of the assembly until after the probe has been put in the tank and riser.

9.3.2 Manhole and Junction Box



NOTE: The section that follows is applicable to the OPW-FMS 924B junction box installation. For information on DMP probe installation and regional installation with an IP68 junction box see [Dover Magnetostrictive Probe \(DMP\)](#) (p. 45) and [DMP Probe Cable Wiring to I.S. Barrier](#) (p. 52).



Install a manhole of at least 45.7 cm (18 inches) diameter around an unused fitting in the top of the tank. This manhole must be of sufficient dimensions to contain the riser for the probe and a weatherproof junction box.



NOTE: The 924B probe cable (OPW P/N 10-1185) is 6 feet (1.83 M) in length. Make sure there is sufficient length of cable from the probe to where a weatherproof junction box is to be installed.

The weatherproof junction box must be of sufficient dimensions to contain a 0.5 inch (12.7 mm) conduit, a minimum 12 inches (30.5 cm) coiled field wiring, all applicable probe and sensor cables and an epoxy resin seal-pack.

Install a 1/2-inch NPT bushing in the weatherproof junction box for the conduit.

 WARNING!	
	Seal-offs are required any time I.S. wiring enters conduit. Install one conduit seal fitting in the manhole where the conduit leaves the junction box and one in the building before the conduit goes into the console. See the Conduit Seal Fittings for Cables section that follows for more information.
	

Probe Installation Scenario

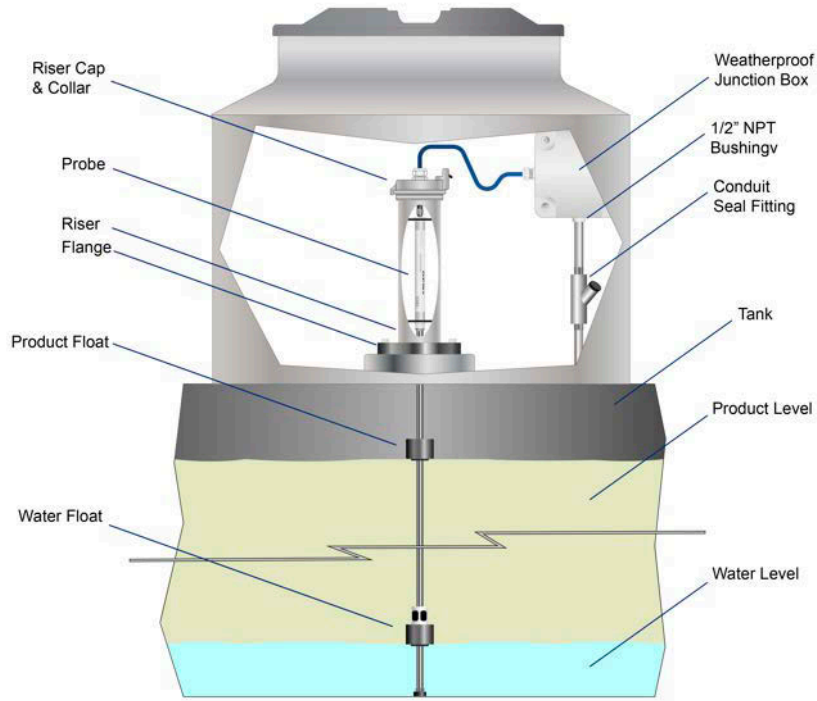

Figure 9-3 924B Probe Installation

DMP Probe Installation Scenario

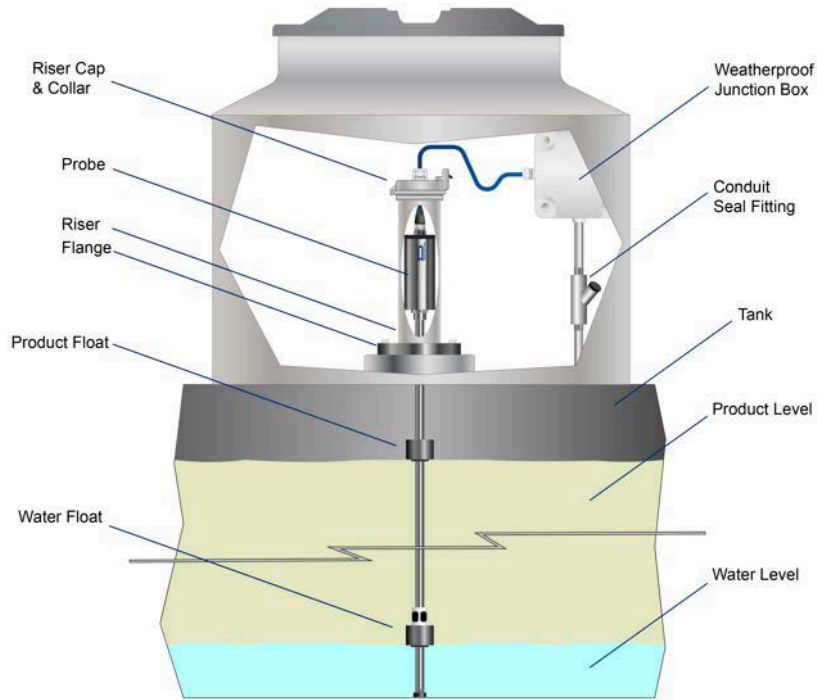

Figure 9-4 DMP Probe Installation

9.4 Conduit Seal Fittings for Cables



IMPORTANT: To comply with Article 501 of the National Electrical Code, Seal-offs must be installed where I.S. wiring enters conduit. Install one conduit seal fitting in the manhole where the conduit leaves the junction box and one in the building before the conduit goes into the console.



WARNING!



The Tank-Probe cables must be sealed **before** they go into the I.S. barrier (explosive fumes can travel through the cable *jacket*). This will keep explosive fumes away from the I.S. barrier.

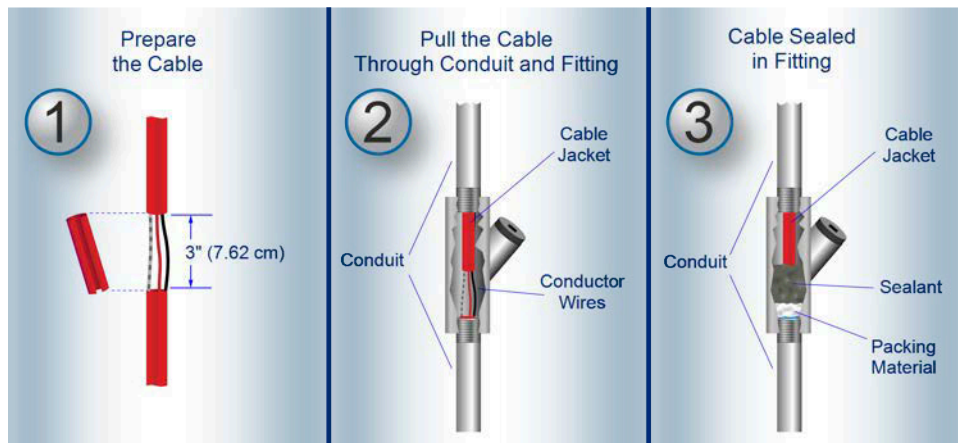

1. Prepare the Cable: Remove a sufficient length of the cable *jacket* so that the *conductor* wires can extend into the conduit seal fitting (approximately 3 inches [7.62 cm]).



IMPORTANT: Make sure you do not cause damage to the *conductor wire insulation*!

2. Pull the prepared Cable through the assembled conduit and fitting so that the *conductor* wires extend into the conduit seal fitting.

3. See the manufacturer's instructions that came with your Conduit Seal Fittings for the correct procedure to fill the seal cavity with an applicable sealing compound.



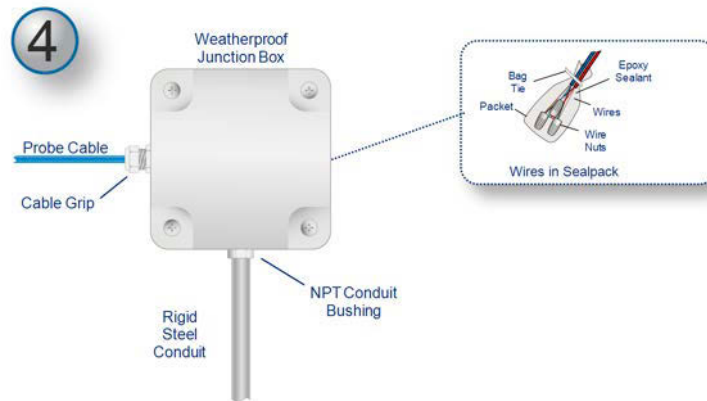

IMPORTANT: Make sure that the open ends of the prepared cable inside the fitting are completely sealed. This will prevent the flow of explosive fumes through the Cable jacket.



4. Tank-Probe or Smart Sensor wires that use a prepared Belden or Alpha cable must go through NPT bushings into a weatherproof junction box. Bushings must be used in all junction boxes.
5. The cable must go through rigid steel conduit from the junction box directly to the I.S. barrier.

6. Put a label on each cable and conductor wire to identify its connection.

 **CAUTION!**

 The console must have a dedicated power circuit and must be on the same phase as all other OPW equipment. Only OPW probe cables and sensor wiring can be in the same conduit that goes to the I.S. barriers.

 **NOTICE!**

Incorrect cables, wiring, or conduit can cause electronic noise interference with probe/sensor measurements. This can cause measurement indications at the console that can show as a hardware error. The warranty is voided if incorrect cables, wiring and/or conduit are installed. The ground wire must be correctly installed for the noise-filtering circuitry to operate correctly. Thus, the conduit must not be used for operation of the ground.



9.5 Probe Installation in Underground Storage Tanks

1. Install a manhole of a minimum of 18 inches (45.7 cm) diameter around an unused fitting in the top of the tank. This manhole must be of a sufficient size to contain a weatherproof junction box together with the probe and riser assembly.



NOTE: *If the fitting is not in the center of the tank, additional measurements are required for probe compensation. If the fitting is not in the center of the tank more measurements will be necessary to maintain the minimum distances between the probe and the fill and sump tubes.*

2. The probe cable (OPW P/N 10-1185) is 6 feet (1.83 M) in length. Make sure there is sufficient length of cable from the probe to where a weatherproof junction box is to be installed.
3. Leave a minimum 12 inches (30.5 cm) of extra, coiled wiring (probe wire and field wire) inside the weatherproof junction box. The box must be large enough to contain a 0.5 inch (12.7 mm) conduit, coiled field wiring and epoxy seal-pack, as shown in the field wiring diagram.

	CAUTION!
	Seal-offs are required any time I.S. wiring enters conduit. Install one conduit seal fitting in the manhole where the conduit leaves the junction box and one in the building before the conduit goes into the console.

4. Install a 1/2-inch NPT bushing in the weatherproof junction box.

10 924B Probe Installation

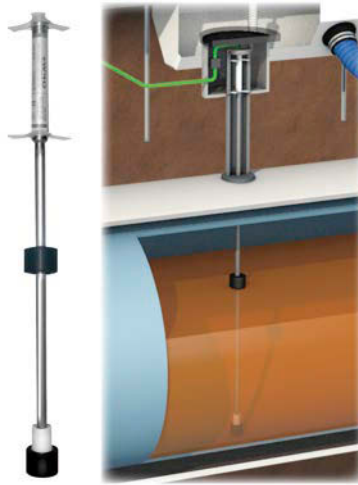

10.1 Probe Floats

There are three types of floats used with the probes: Product, Water for Diesel, and Water for Gasoline.



IMPORTANT: The two types of water floats are NOT interchangeable. Because diesel has more density than gasoline, the diesel floats are heavier than the gasoline floats. If an incorrect water float is installed in a diesel tank, it will not go through the product to the water below. As a result, the fuel tank will have unusually high water measurements. This can also cause irregular product measurements because the water float can cause interference with the product float.



Probe Type/Float Style	Float Kits
924B 2" (5.1 cm) Floats:	Gas: 30-1509-02 Diesel: 30-1509-01



NOTICE!

The product float for LPG is not approved for installations where it can be pressurized at or more than 300PSI. Pressures higher than 300PSI will damage the device and it will not be easy to get accurate measurements.

10.2 Model 924B Probe Specifications

	CAUTION!
	<p>Special Conditions for Safe Use: Static electricity can cause fires. To prevent static electricity in the probe, do not rub or clean the probe with a cloth. Make sure to release static electricity from the probe in an area away from the hazardous area before it is installed. These devices have not been approved for use across a boundary wall. The housing cover at the top of the probe is made of aluminum. To avoid ignition hazards do not let the head hit or rub against another object.</p>

924B Magnetostrictive Probe Specifications	
Power Requirements:	Nominal 12+ VDC from I.S. Barrier
Operating Temperature:	-40°C to +70°C (-40°F to 158°F)
Maximum Total-Run Wiring Length ¹ :	305 m (1,000 feet) Belden 88760 or Alpha 55371 152 m (500 feet) Belden88761 (or equivalent)
Level Measurement, Product:	± 0.0127 mm (± 0.0005 inches)
Level Measurement, Water:	± 0.254 mm (± 0.012 inches)
Temperature Resolution/Accuracy:	± 0.1°C / ± 0.5°C
Classifications:	Class I, Division 1, Group D
Certifications:	IECEX UL 11.0012X
	DEMKO 11 ATEX 1012670X
I.S. Barrier Used:	12V ONLY; OPW P/N: 20-4344 (Green Label)
Multi-drop Restriction ² :	924B is the only probe that can be multi-dropped at a maximum of three(3) probes per channel
Connections:	Blue = Power, Brown = Signal, Black and Shield = Ground

1. This is the maximum length of wire to be used to connect all probes on one channel. This length includes the wire from the I.S. barrier to each probe in the string.
2. ONLY 924B Probes made after September 1, 2007, (version 7.xx firmware) can be installed in a multi-drop installation.

11 Dover Magnetostrictive Probe (DMP)

11.1 DMP-IS Technical Characteristics

RS 485 Serial Communication for Multi-point Connection

- Power supply 12 VDC through an intrinsically safe barrier.
- Consumption <20 mA @ 12 Vdc normal functioning
- Connection cable: hydrocarbons resistant, suitable for underground pose with insulation 0,6-1 KV, 2 shielded and twisted pairs, section of the power cable pair of at least 1 mm².
- Type of cable supplied by Start Italiana for backbone connection:
LiYstCYY INSULATION LEVEL 4 (0,6/1 KV) - (2x0.25mm²) + (2x1 .00mm²) CEI 20-2211 IEC 60332-3A ENI 00.181.00
- Type of cable supplied by Start Italiana with the probe (1.5mt):
LiYstCYY INSULATION LEVEL 4 (0,6/1 KV) - (4x0.25mm²) CEI 20-2211 IEC 60332-3A ENI 00.181.00
- Maximum transmission distance: up to 2 Km based on standard of RS485 interface.

Measurement Characteristics

- Electronics based on a Microprocessor
- Support telediagnosics and telemaintenance (only wired version RS485)
- Possibility to configure remotely the functional parameters
- In case of maintenance the internal part of the sensor (wave guide) can be removed without degas the tank, especially useful for LPG applications where the tanks are in pressure.
- Tank connection:
 - Not needed if probe is inserted into a riser with internal diameter 2"
 - 2" sliding connection as standard.
 - Other type of optional connections under request (nipped fixed, flanged, ...)
- Stainless steel and composite caps case, IP68.
- Probe shaft Stainless Steel AISI 304 / 316
- Measurement range: from 200 mm. to 5000 mm.
- Data transmitted:
 - Product level in 0.01 mm
 - Water level in 0.01 mm
 - Medium temperature detected through digital temperature sensor placed along the probe shaft (max 5)
 - Density range (option): 600-900 Kg/m³
 - Density Accuracy (option): 3 Kg/m³
 - Measurement accuracy: < 0.2 mm.
 - Measurement resolution: +/- 0,01 mm. (+/- 0.0001 mm for EPA option)

- Measurement repeatability: +/- 0,05 mm.
- Temperature accuracy: +/- 0,2°C (up to 5 temperature sensor option is available for static leak test)
- Temperature resolution: 0.0625° (0.0001 °C for EPA option)

Approvals

- ATEX
- PESO
- UL
- UL_BR
- IECEx
- OIML-R85
- EPA

11.2 DMP Probe Installation

The Dover Magnetostrictive Probe (DMP) is installed almost the same as a 924B Probe.



IMPORTANT: To prevent damage to the probe, be careful when you remove the probe from its packaging and when you install it in a tank. Do not let probe components hit the sides of manholes or tank openings. Make sure the stainless steel probe shaft does not get bent. This can cause incorrect indications in fluid levels.



IMPORTANT: If the fitting is not in the center of the tank, a [Product Offset Calculation](#) will be necessary. See [Product Offset Calculation](#) (p. 35) for information.

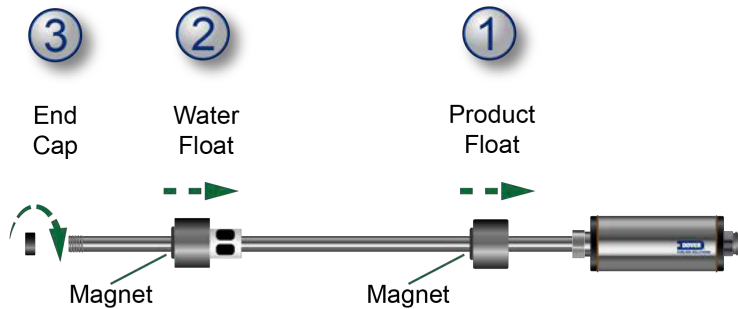

Figure 11-1 DMP Probe with OPW-FMS Floats

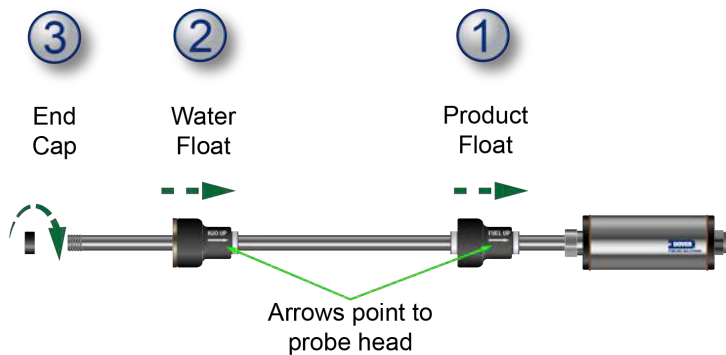

Figure 11-2 DMP Probe with ProGauge Floats

The DMP probe is shipped fully assembled. You can skip to step 4 to install an assembled probe. If it becomes necessary to disassemble the probe components, use steps 1-3 below to assemble the floats and end cap to the probe before you continue.

1. Put the Product Float on the probe shaft. Make sure the magnet side points toward the bottom of the probe shaft for FMS Floats. Make sure the arrow points toward the probe head for ProGauge floats.
2. Put the Water Float on the probe shaft (if applicable). Make sure the magnet side points toward the bottom of the probe shaft for FMS Floats. Make sure the arrow points toward the probe head for ProGauge floats.
3. Attach the End Cap to the end of the probe shaft. Turn it clockwise to tighten.

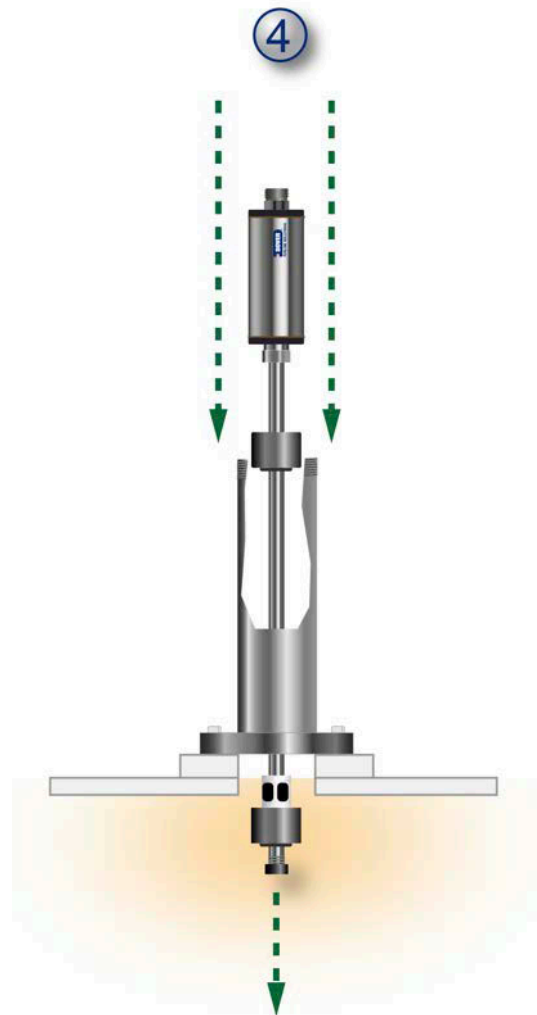

Figure 11-3 DMP Probe with FMS Floats

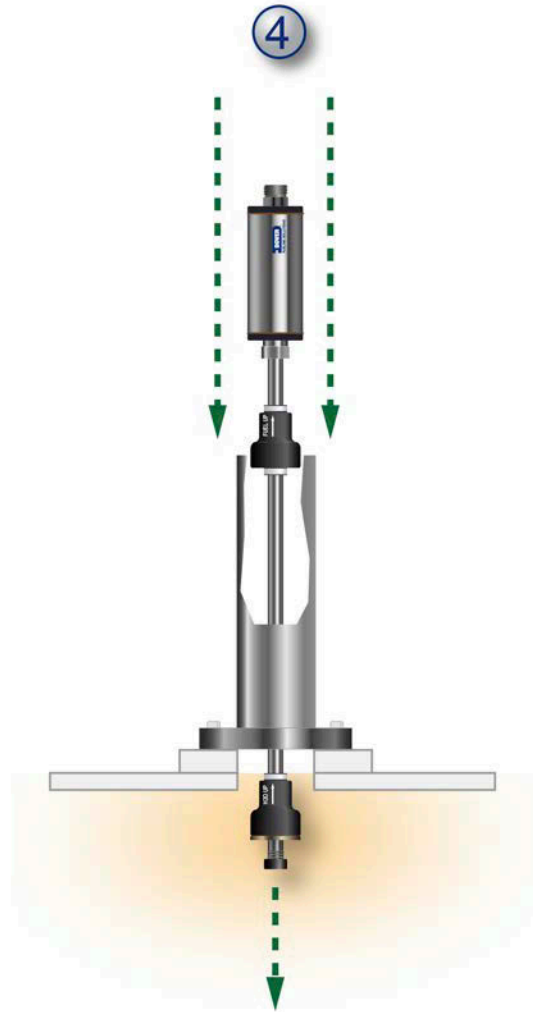

Figure 11-4 DMP Probe with ProGauge Floats

- Carefully put the assembled probe down through the riser into the tank until the probe end cap touches the bottom of the tank.



NOTICE!

Carefully lower the probe down into the tank. To prevent damage to the probe, do not let the probe fall and hit the bottom of the tank wall.

- Connect the 7/8" probe cable connector to the probe.



NOTE: The DMP cable is 1.5 M (3.28 ft.) by default but can be ordered with a different specified length.

11.3 Spacer Assembly (6-3/4 RA SS) and Adjustment



IMPORTANT: *The minimum inner diameter for a riser is 52 mm (2.05 in.). This gives an allowance for the head gaskets so the probe can move freely inside the riser*

The DMP Probe can be installed in a minimum 52 mm (2.05 in.) inner diameter riser without modification. If the probe is to be installed in a riser with an inner diameter up to 4-inches (101.6 mm), a spacer must be installed. This will keep the probe in the center of the riser and in a vertical position through the bottom of the tank.

The Probe Spacer kit contains:

- One (1) stainless steel, flexible spacer.
- Two (2) M3x8 screws
- Two (2) M3 nuts

DMP Spacer Assembly and Adjustment

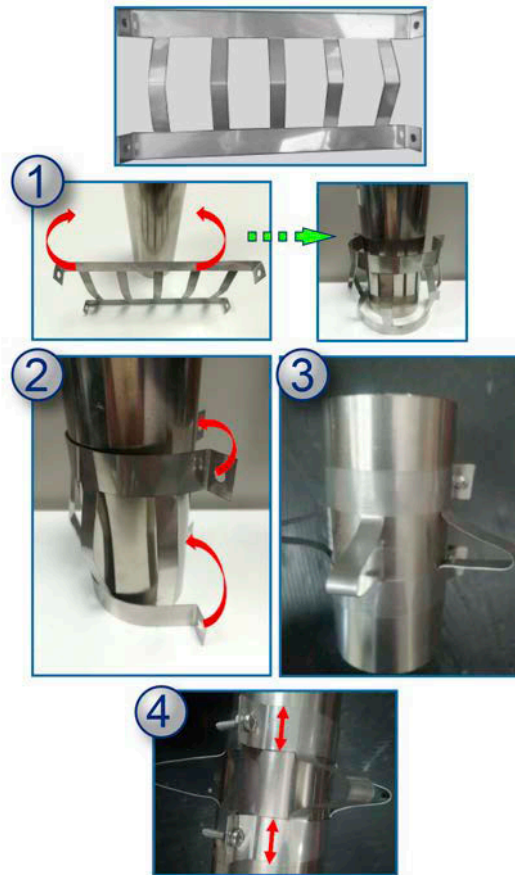

NOTICE!

Be careful to not cause damage to the probe label when you install or when you make adjustments to the spacer. The label contains important safety and product information.

To assemble and adjust the probe spacer:

1. Bend the probe spacer around the probe head.
2. Align the holes of the 90° bends of the top and bottom strips.
3. Put the two (2) screws through the two (2) pairs of holes and fasten with the two (2) nuts. Do not tighten the screws completely at this time.
4. To adjust the width of the spacer, move the top and bottom strips nearer to or away from each other. This will cause the outer diameter of the vertical strips to move in or out until you find the correct fit inside the riser. When the correct fit has been found, tighten the screws completely.

11.4 DMP Probe Cable Wiring to I.S. Barrier

11.4.1 DMP wiring to Belden 88770



NOTE: Belden 88770 is the recommended cable. However, Belden 88760 (or equivalent) is a satisfactory alternative for most environments/installations.

DMP Wiring to Belden 88770 Field Wiring

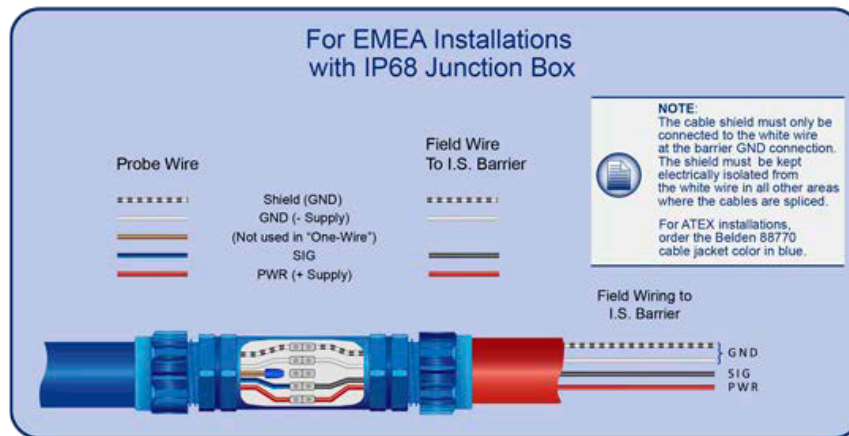
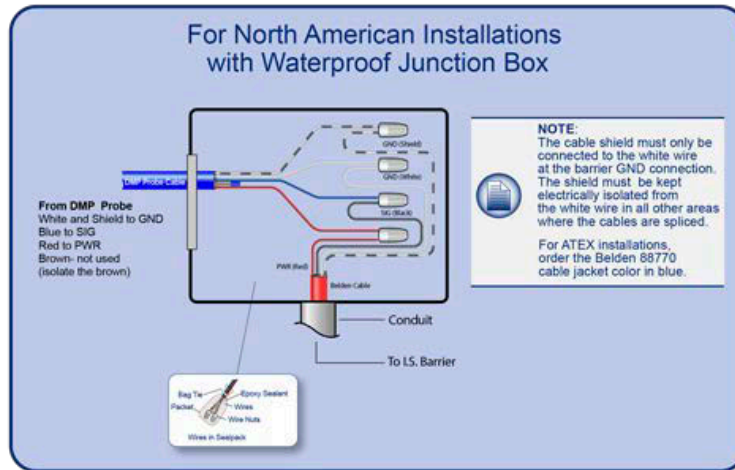

For new DMP installations it is recommended to use Belden 88770 for field wiring. The top illustration above shows the wiring of the DMP Probe "One-Wire" to typical field wiring in a waterproof junction box for installations in North America. The bottom illustration shows the wiring of the DMP "One Wire" in an IP68 rated junction box for EMEA installations.

11.4.2 DMP wiring to Belden 88760



NOTE: This is for wiring installations that have Belden 88760 (or equivalent) cable installed before the installation of new probes. New installations should use Belden 88770 if possible (see the section above).

DMP wiring to Belden 88760 (or equivalent) Field Wiring

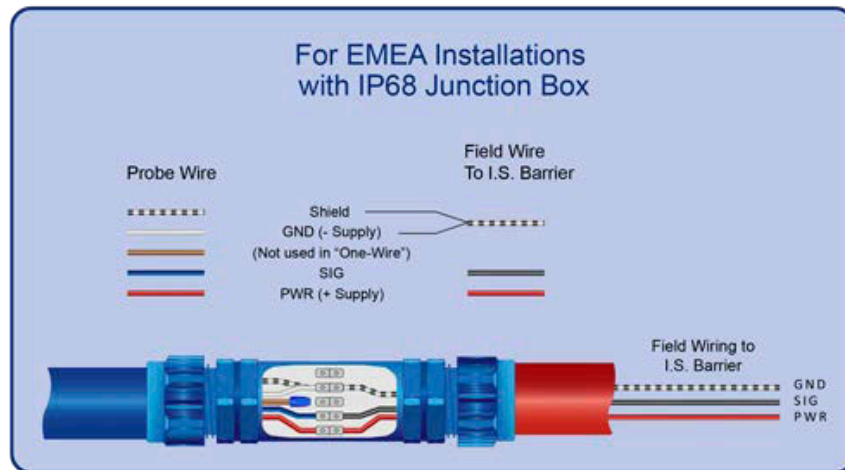
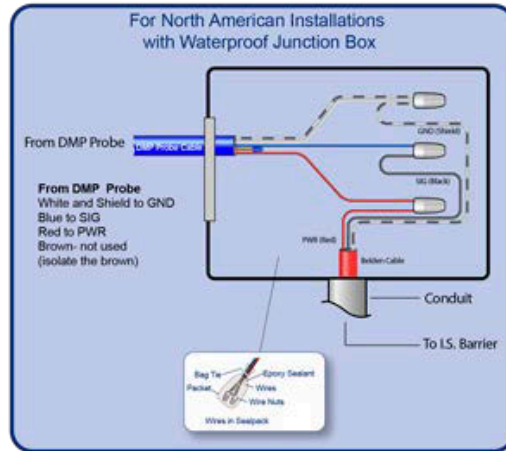

The illustrations above show how to install existing Belden 88760 field wiring with new DMP Probes. The top illustration above shows the wiring of the DMP Probe "One-Wire" to typical field wiring in a waterproof junction box for installations in North America. The bottom illustration shows the wiring of the DMP "One Wire" in an IP68 rated junction box for EMEA installations.

12 Density Measurement Float (DMF)

OPW Part Number 20-4431 (Gas - White Core) & 20-4432 (Diesel - Black Core)

The Density Measurement Float (DMF) can be installed on a pre-existing probe. The DMF continuously measures the average density of the fuel in the tank. This can measure the smallest change in product density in the API density range. Fuel-density reports can be shown real-time on the console or exported to an external device. The readings can be a nominal or temperature-corrected density.

There are two (2) types of the DMF. One that measures density for gasoline (20-4431) and another for diesel (20-4432). They can be identified by the white core of the gasoline float or the metal weight of the diesel float. See the image below.

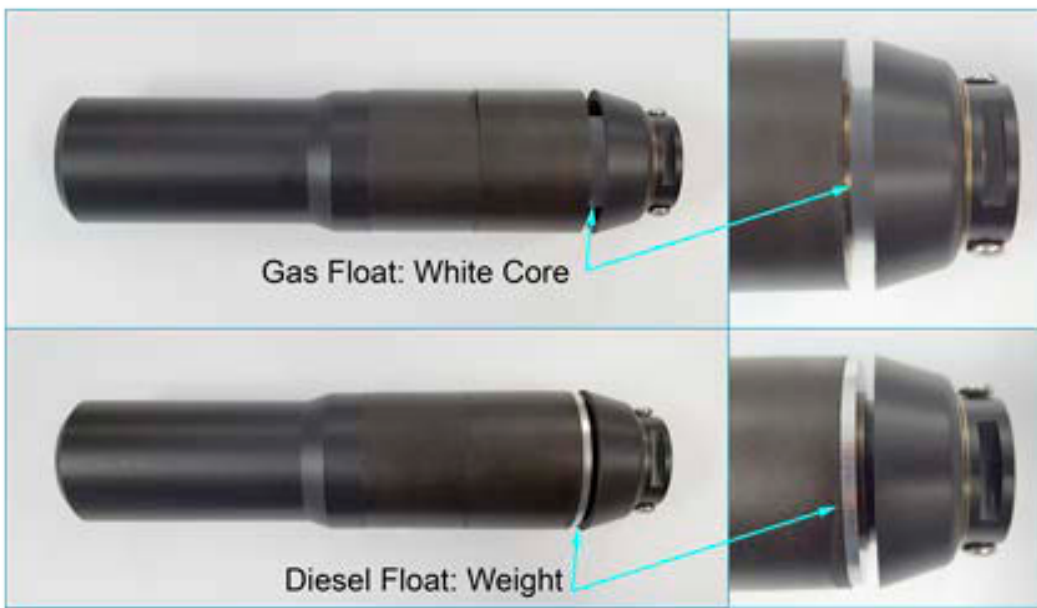

Density Measurement Float Specifications	
Materials:	Nitrophyl, Delrin, and Stainless-Steel spring
Dimensions:	Length: 20.3 cm (8 inches) Diameter: 5.1 cm (2 inches)
Accuracy:	3 kg/m ³
Suggested Location:	15.2 cm (6 inches) from the bottom of the probe NOTE: Use two (2) set screws at the top of the float to hold it in position

Product Density and Chemical Compatibility			
Product Group	Compatibility	API	Specific Gravity
Gasoline	Gasoline	45 < API < 78	0.68 < d < 0.80
	Aviation Gasoline		
	Regular Unleaded		
	Regular Leaded		
	Premium Unleaded		
	Gasoline/Methanol blend, < 5% methanol Gasohol, < 40% ethanol		
Diesel	Diesel	26 < API < 45	0.80 < d < 0.90
	Jet Fuel		
	Kerosene		
	Motor Oil		
	Toluene		
	Gear Oil		
	Transmission Oil		

12.1 DMF Installation

WARNING!



THIS IS A STATIC SENSITIVE DEVICE! To prevent the risk of explosion from static discharge, do not clean or rub this device with a dry cloth.

NOTICE!

To prevent damage to the I.S. barrier, you must turn off the power to the module that the probe is connected to before you begin the procedure below.

1. Turn off the power to the module that the probe is connected to before you remove the probe from the tank.
2. Remove the probe from the tank and remove the clip and the nylon probe foot from the bottom of the probe.
3. Remove the water float. Put the density float on the probe shaft (make sure the top of the float points toward the probe head) and tighten the screws of the float (the screws are at the top of the float). Keep a space of 10.2 cm to 15.2 cm (4 to 6 inches) at the bottom of the probe shaft so the water float can detect at least 7.6 cm (3 inches) of water.
4. Put the water float, nylon probe foot and end clip back on the probe shaft.
5. Put the probe back in the tank.

6. Turn on the power to the module.

For DMF configuration and calibration refer to the M2051 LX 4/LX Plus Configuration Manual. You will need the A and B Factors that are etched into the body of the float. See the image below.



 **NOTICE!**

The Density Measurement Float is not to be used in a pressurized tank.

12.2 Tank Thresholds

- Make sure that the Density float is installed between the Water Float and the Product Float. When you set the product threshold levels (*Low* and *Low-Low*) in the console's **Tank Thresholds** screen, make sure the values are higher than where the Density Float is installed. Refer to your console's configuration guide.
- Measure the distance between the end of the probe shaft and the top end of the Density Float. Add 5.1 cm (2 inches) to this distance to include the dead zone at the end of the probe. The result is the value of the minimum *Low-Low* product threshold.

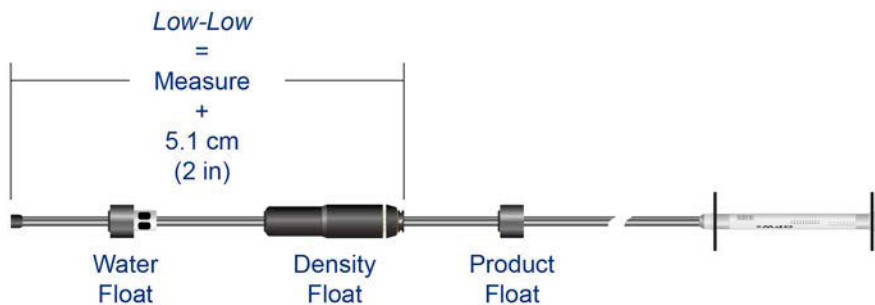

Figure 12-1 Calculate Low-Low Threshold

13 DMP Density Measurement Float



The Density Measurement Float measures continuously the average density of the fuel in the tank and it can be installed on the DFS DMP Probe.

This float can measure the smallest change in product density within the specific density range and these readings can be either nominal or temperature-corrected density.

These density measures can be shown real-time on the console Maglink LX4 or exported to an external device.

There are 2 version of the Density Measurement Float:

- (6-DMP-DF GK) which measures density for gasoline
- (6-DMP-DF DK) which measures density for diesel

They can be identified by the number of bottom steel ring as the images below:

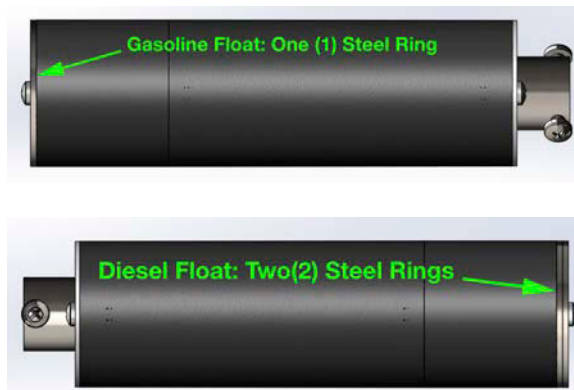

DENSITY MEASUREMENT FLOAT SPECIFICATIONS	
Materials	Polyacetal – NBR – Stainless steel
Dimensions	Total length: 185mm (for Diesel) – 183mm (for Gasoline) Diameter: 49.8mm
Density Range	680kg/m ³ – 800kg/m ³ for Gasoline 800kg/m ³ – 900kg/m ³ for Diesel

13.1 DFS Density Measurement Float Installation



WARNING!



THIS IS A STATIC SENSITIVE DEVICE! To prevent the risk of explosion from static discharge, **do not** clean or rub this device with a dry cloth.

1. Shut down the module that the probe is connected to. Then, remove the probe from the tank.



2. Turn the bottom Probe Ring counter-clockwise to unscrew the ring from the probe. Then, remove the water float.

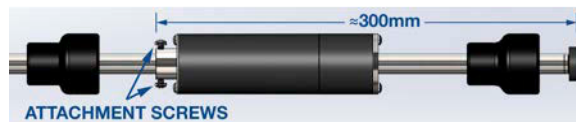

3. Put the density float onto the probe shaft so the two attachment screw point toward the top of the probe. Tighten the 2 attachment screws to the probe shaft.



NOTE: The float should be installed so that the top of the float is approximately 300mm from the probe bottom.

4. Put the Water Float back on the Probe Shaft. Put the bottom Probe Ring back on the threads and turn it clockwise to tighten it.
5. Put the probe back inside the tank.
6. Supply power up the system.
7. For Density Measurement Float configuration and calibration, refer to your Console Configuration Manual.



8. For the configuration and calibration, you will need the A and B parameters printed on the body of the float. These parameters are also written on the label inside the float packaging.



NOTICE!

The Density Measurement Float is not to be used in a pressurized tank.

13.2 Tank Thresholds

- When the Density Float is installed, the Product Float cannot be installed between the Water Float and the Density Float. The product Float must be installed above the Density Float.
- The Low Product Alarm must be set above the Density Float.



- To set the Low-Low Product Alarm, measure the distance X and add 50mm (where the distance X is from the bottom of the probe to the top of the Density Measurement Float).

13.3 Calibration on First Installation

To have a correct density reading the Density Measurement Float has to be put fully in the fuel. During the first installation it is recommended to do a calibration with a third-party density meter (hydrometer); the B parameter will change according to the alignment.

The calibration process will be shown in the configuration section of your console.

The density kit can lose its calibration because of the weight of possible contamination.

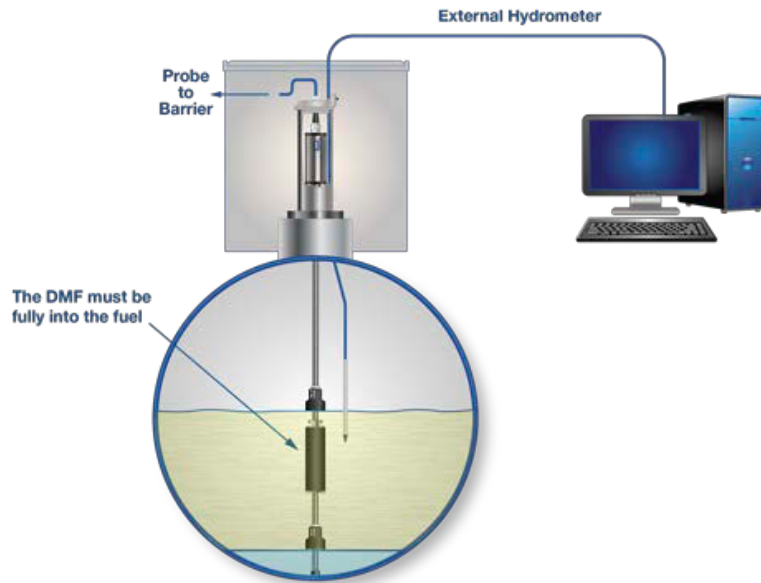

14 Sensor Support

The MagLink LX-series consoles support OPW-FMS Smart Sensors that use IntelliSense™ Technology. The OPW smart sensors can monitor all contained areas of the fuel-storage system: tank interstice, piping sumps, STP containment sumps, dispenser sumps and pans, monitoring wells and site locations. Sensors connected to the I.S. barrier are automatically detected and identified by the console.

14.1 IntelliSense Technology



This technology lets the console's internal I.S. barrier automatically find the sensor's connection, type and status. IntelliSense will minimize user entry errors and identify hardware issues with minimal troubleshooting.

14.2 Mixed Multi-Drop Installation

Mixed Multi-Drop technology can run probes and sensors on one cable back to the tank gauge.



IMPORTANT: Seal packs and weatherproof junction boxes are **REQUIRED** with **ALL** I.S. field connections for North American installations.

14.3 Smart Sensors

Part Number	Description
30-0232-DH-10	Discriminating Dispenser Sump Sensor
30-0232-DH-20	Discriminating STP Sump Sensor
30-0236-LW	Discriminating Interstitial Sensor (Optical)
30-0234-HW-06/15/20	Hydrocarbon Liquid Sensor with water indicator (6, 15 and 24 ft. lengths)
30-0234-HW-01	Interstitial Hydrocarbon Liquid with water indicator
30-0231-S	Interstitial Sensor-Float Switch – (Small Plastic)
30-0231-L	Sump Sensor-Float Switch – (Large Plastic)
30-0230-S	Liquid Only Float Sensor (Brass) - steel tank interstitial containment area
30-0232-D-10	Dual Float Non-Discriminating Dispenser Sump Sensor
30-0232-D-20	Dual Float Non-Discriminating STP Sump Sensor
30-0232-D-10B	Dual Float Brine Sensor for Containment Sump
30-0232-D-20B	Dual Float Brine Sensor for Fiberglass Tanks
30-0235-V	Hydrocarbon Vapor Sensor

14.4 Interstitial Level Sensor

14.4.1 Smart Sensor Equipped with Intellisense™ Technology

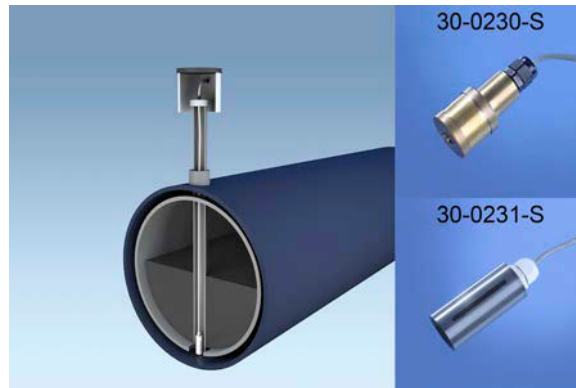
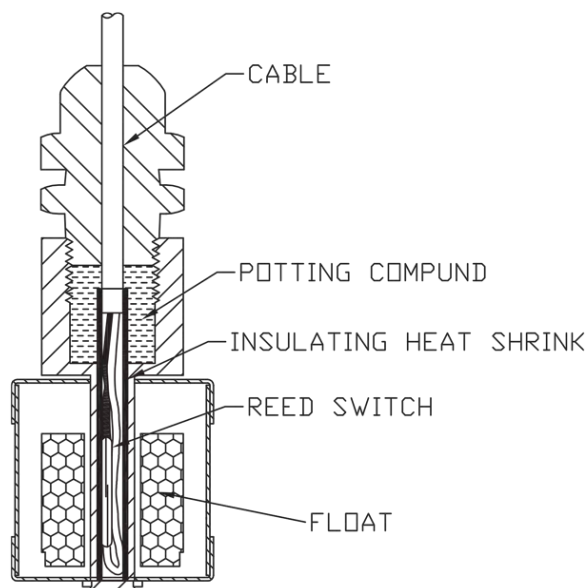

Figure 14-1 30-0230-S Liquid Only Float Sensor (Brass) & 30-0231-S Interstitial Sensor-Float Switch

14.4.2 Description

The primary function of these sensors is to sense liquid in the interstitial area of a double-walled steel tank (these sensors are not for use in a double-walled fiberglass tank). A float inside the sensor moves up when the liquid level increases. The float switch will operate and cause an alarm condition in the controller. The 30-0230-S is made of brass and the 30-0321-S is made of a chemical resistant, non-metallic material.

These sensors can also be used in sumps, fuel dispenser pans and other locations where there is liquid that could indicate that a leak has occurred. These sensors can also be used together with a vapor sensor (30-0235-V) to monitor wet wells to make sure that there is a normal liquid level. If there is a break in the cable it will cause an alarm condition in the system.



Specifications	
Primary Use:	30-0230-S: STP Sumps and Fuel Dispenser Pans 30-0231-S: Interstitial Area
Alternate Use:	30-0230-S: Steel Tank Interstitial 30-0231-S: Sumps and Fuel Dispenser Pans
Detects:	Liquid
Operating Temperature:	-20°C to +50°C (-4°F to +122°F)
Dimensions - 30-0231-S	Diameter: 1.3 inches (3.4cm), Length: 3.9 inches (10 cm)
Cable Requirements:	Belden #88760 or Alpha #55371 4.5m (15 feet) of gas & oil resistant cable to the inline ISIM + 1.3m (4 feet) ISIM tail.
Maximum Wiring Length ¹ :	1,000' (305 m) field wiring
Alarm Threshold Configuration:	Fully Automatic
Diagnostic Reading on sensor setup:	0 - 0.5 (normal), 485 - 495 (in alarm)
Multi-Drop Restriction	Maximum points per channel = 12 points, 924B and DMP Probes = 4 points, ISIM Smart Sensors = 1 point Devices can be mixed in any combination to hold a maximum of 12 points on one channel
Connections:	Red = Power, Black = Signal, Shield = Ground

1. This is the maximum length of wire to be used to connect all sensors on one channel. This length includes the wire from the Barrier to each sensor board in the string.

14.4.3 Installation

NOTICE!

Make sure you read and fully understand the warnings and information found in the **Hazardous Areas** section of your console's Installation Guide before you install or do the servicing of this sensor.

IMPORTANT: *This Smart Sensor must ONLY be connected to an OPW Fuel Management Systems 12V VSmart Module. This will make sure that operation conditions are safe. Smart Sensors CANNOT be used with SS1, 2 or 3, iTouch or EECO consoles.*

CAUTION!

ALWAYS obey Local and National Electrical Codes applicable to the installation location.

 Make sure that the cables (gas and oil resistant OPW Fuel Management Systems part # 12-1030) from the field wiring to the controller are in conduit that is dedicated to intrinsically safe wiring.

Use wire-nuts and epoxy-resin seal-packs for field connections (refer to M00-390008 Waterproof Electrical Connections for information).



NOTE: *If this sensor is used to monitor a normally dry well, use a meter to set the float position so the sensor is in a closed position when there is NO liquid level (the float will be in the lower position). To monitor a normally wet well, use a meter to set the float so that the sensor is in a closed condition WITH a liquid level (the float will be in the upper position).*

- This sensor uses ONE Controller Interface I.S. Module position
- Start with the Connections table and "Typical Installation" drawing below.
- Make sure the sump pit or pan is dry.
- Install the sensor approximately 1/2" (1.3 cm) above the bottom of the sump/pan. Attach the sensor wire to a pipe or bracket with a tie wrap.
- Connect the sensor cable to the sensor.
- Connect the sensor wires to the field wires in the junction box. Use the supplied cable gland and silicon wire nuts.
- Seal the electrical connections with the epoxy seal packs (refer to M00-390008 Waterproof Electrical Connections for instructions).
- Install explosion-resistant sealing fittings at both ends of the conduit. Refer to the **Probe-Cable Seal-offs** section of the console's Installation Guide for instructions.

14.4.4 Connections

Sensor Wire Color	12V Smart Sensor Interface Channel
Red	Power
Black (hydrocarbon sensor)	Signal
Shield (or 3rd conductor)	Ground

14.4.5 Typical Installation Drawings

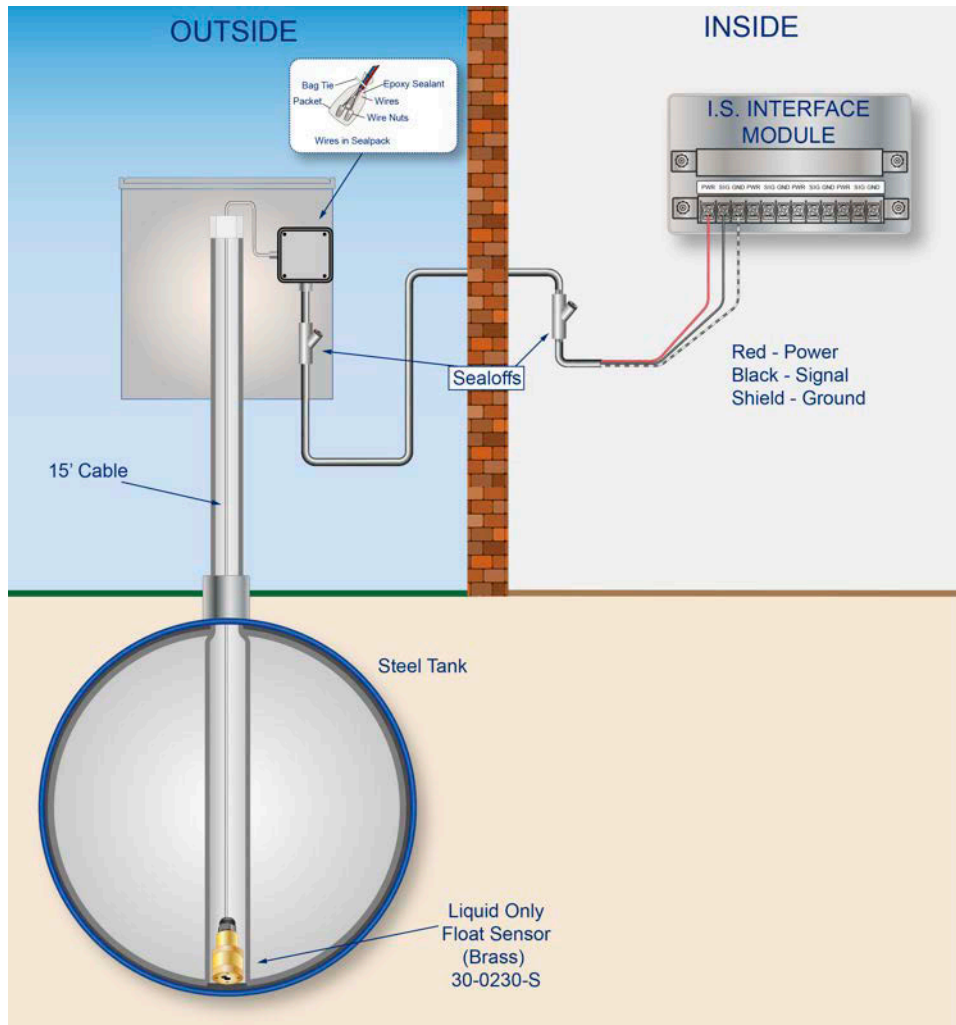

Figure 14-2 30-0230-S

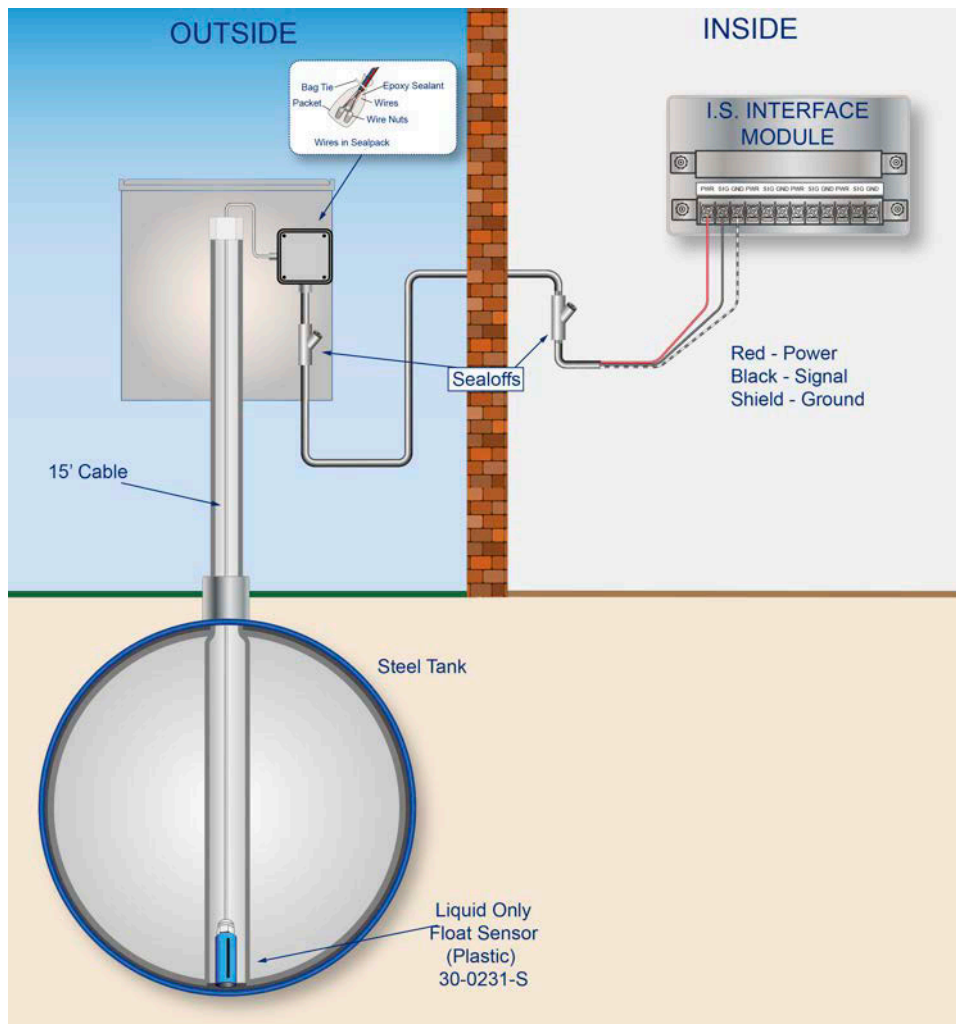



Figure 14-3 30-0231-S

14.4.6 Controller Setup

The sensor must be **Auto Detected** on the console. Refer to the M2051 MagLink LX4/LX Plus/Ultimate Configuration Manual, Admin Account > System Settings > Site Info for information for information about *auto-detection*. Alarm thresholds are configured automatically through the *Intellisense* mechanism between the sensor and the console.

14.4.7 Float Sensor Test

		CAUTION!
	Use caution to prevent dangerous conditions when you do work in a hazardous area.	
	Make sure that the area has sufficient airflow when you do a test or remove contamination from the sensor. Make sure there are no open flames or hot surfaces near the work area.	

Sensor installed in a normally dry well

- Put the float in the HIGH position. This will cause an alarm condition in the controller.
- Put the float back in the LOW position. Make sure that the controller is not in an alarm condition.

Sensor installed in a normally wet well

- Put the float in the LOW position. This will cause an alarm condition in the controller.
- Put the float back in the HIGH position. Make sure that the controller is not in an alarm condition.

If the controller does not go into an alarm condition, look to see if the thresholds are correctly programmed in the system. Look to see if the float is in the correct position (refer to the applicable instruction above). A sensor or wiring fault will cause a system alarm. Do a continuity test in the wiring and junction boxes. Make sure there is continuity with no short circuits.

14.5 Single Level Sump Sensor-Float Switch

14.5.1 Smart Sensor Equipped with Intellisense™ Technology

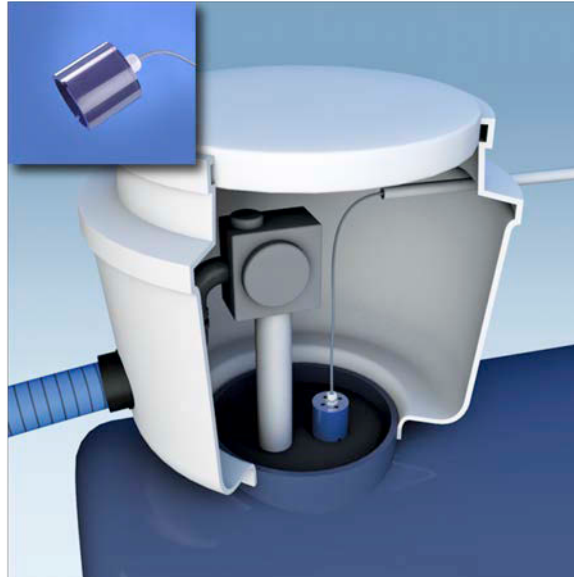
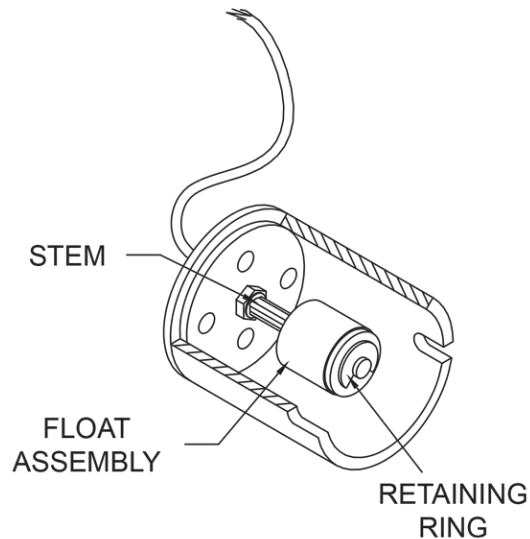

Figure 14-4 30-0231-L

14.5.2 Description

The primary function of the single-level sensor is to sense liquid in sumps, fuel dispenser pans and other locations where there is liquid that could indicate that a leak has occurred. A float inside the sensor moves up when the liquid level increases. The float switch will operate and cause an alarm condition in the controller. If there is a break in the cable it will cause an alarm condition in the system.



Specifications	
Primary Use(s):	Sumps and Fuel Dispenser Pans
Detects:	Liquid
Operating Temperature:	-40°C to +70°C (-40°F to 158°F)
Dimensions:	Diameter: 7.4 cm (2.90 inches), 9.5 cm (3.70 inches)
Cable Requirements:	Belden #88760 or Alpha #55371 3.6m (12 feet) of gas & oil resistant cable to the inline ISIM + 1.3m (4 feet) ISIM tail.
Maximum Wiring Length ¹ :	305 m (1,000 ft.) field wiring
Alarm Threshold Configuration:	Fully Automatic
Diagnostic Reading on sensor setup:	0 to 0.5 (normal), 485 to 495 (in alarm)
Multi-Drop Restriction	Maximum points per channel = 12 points, 924B and DMP Probes = 4 points, ISIM Smart Sensors = 1 point Devices can be mixed in any combination to hold a maximum of 12 points on one channel
Connections:	Red = Power, Black = Signal, Shield = Ground

1. This is the maximum length of wire to be used to connect all sensors on one channel. This length includes the wire from the Barrier to each sensor board in the string.

14.5.3 Installation



NOTICE!



Make sure you read and fully understand the warnings and information found in the **Hazardous Areas** section of your console's Installation Guide before you install or do the servicing of this sensor.

CAUTION!

ALWAYS obey Local and National Electrical Codes applicable to the installation location.



Make sure that the cables (gas and oil resistant OPW Fuel Management Systems part # 12-1030) from the field wiring to the controller are in conduit that is dedicated to intrinsically safe wiring.

Use wire-nuts and epoxy-resin seal-packs for field connections (refer to M00-390008 Waterproof Electrical Connections for information).



NOTE: *If this sensor is used to monitor a normally dry well, use a meter to set the float position so the sensor is in a closed position when there is NO liquid level (the float will be in the lower position). To monitor a normally wet well, use a meter to set the float so that the sensor is in a closed condition WITH a liquid level (the float will be in the upper position).*

- This sensor uses ONE Controller Interface I.S. Module position
- Start with the Connections table and "Typical Installation" drawing below.
- Make sure the sump pit or pan is dry.
- Install the sensor on the bottom of the sump/pan. Attach the sensor wire to a pipe or bracket with a tie wrap.
- Connect the sensor cable to the sensor.
- Connect the sensor wires to the field wires in the junction box. Use the supplied cable gland and silicon wire nuts.
- Seal the electrical connections with the epoxy seal packs (refer to M00-390008 Waterproof Electrical Connections for instructions).
- Install explosion-resistant sealing fittings at both ends of the conduit. Refer to the **Probe-Cable Seal-offs** section of the console's Installation Guide for instructions.

14.5.4 Connections

Sensor Wire Color	12V Smart Sensor Interface Channel
Red	Power
Black (hydrocarbon sensor)	Signal
Shield (or 3rd conductor)	Ground

14.5.5 Typical Installation Drawing

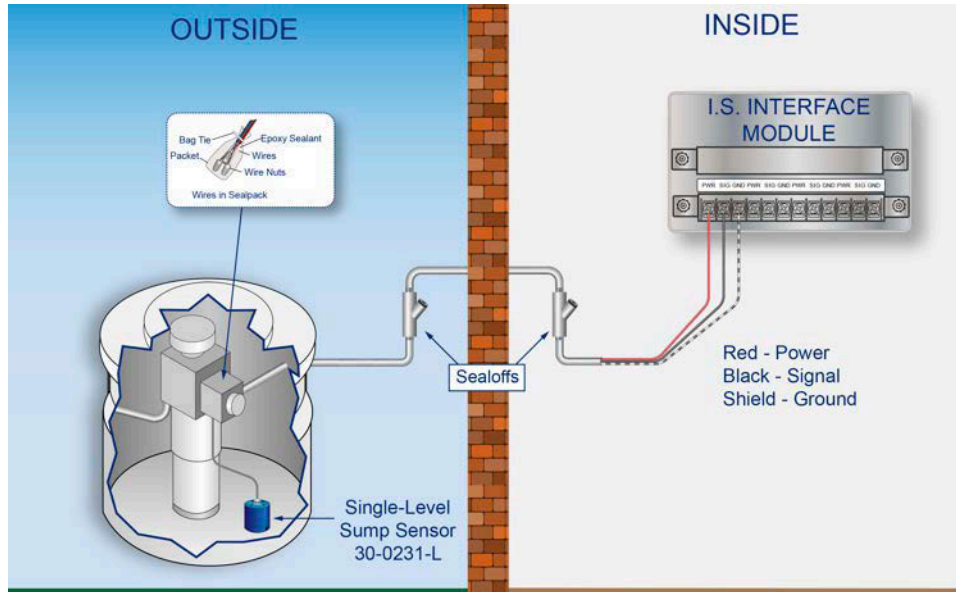

14.5.6 Controller Setup

The sensor must be **Auto Detected** on the console. Refer to the M2051 MagLink LX4/LX Plus Configuration Manual, Admin Account > System Settings > Site Info for information for information about *auto-detection*. Alarm thresholds are configured automatically through the *Intelli-sense* mechanism between the sensor and the console.

14.5.7 Float Sensor Test

 **CAUTION!**

Use caution to prevent dangerous conditions when you do work in a hazardous area.

 Make sure that the area has sufficient airflow when you do a test or remove contamination from the sensor. Make sure there are no open flames or hot surfaces near the work area.

- Turn the sensor so the bottom opening points up and wait for a minimum of two (2) minutes.
- Make sure that the controller is not in an alarm condition.
- Put the sensor back in its normal position. Make sure that the alarm condition stops.

If the controller does not go into an alarm condition, look to see if the thresholds are correctly programmed in the system. Look to see if the float is in the correct position (refer to the applicable instruction above). A sensor or wiring fault will cause a system alarm. Do a continuity test in the wiring and junction boxes. Make sure there is continuity with no short circuits.

14.6 Dual Float Non-Discriminating Sensors

14.6.1 Smart Sensor Equipped with Intellisense™ Technology



Figure 14-5 30-0232-D-10 Dispenser Sump Sensor & 30-0232-D-20 STP Sump Sensor

14.6.2 Description



IMPORTANT: This float body is the same as the 30-0232-D-10B / D-20B and 30-0232-DH-10 / DH-20 (DH-XX has a carbon-polymer strip in the bottom). Look at the label to make sure you have the correct sensor for the applicable function.

The primary function of the Dual Float Non-Discriminating Sensor is to sense liquid hydrocarbons and water in sumps, fuel dispenser pans and other locations where there is liquid that could indicate that a leak has occurred. This sensor looks almost the same as the 30-0232-DH-XX but is non-discriminating. This means that the sensor does *not* use a carbon/polymer material to sense liquid hydrocarbons. Use the D-10 on fuel dispenser pans and transition sumps. Use the D-20 in tank sump pits. Two (2) float switches are used in the body of the sensor to sense low and high liquid levels. If there is a break in the cable it will cause an alarm condition in the system.

Specifications	
Primary Use(s):	D-10: Fuel Dispenser Pan/Sump D-20: STP Sumps
Alternate Uses:	D-10: STP Sumps D-20: Fuel Dispenser Pan/Sump
Detects:	Low Liquid, High Liquid, Fuel (non-discriminating)
Operating Temperature:	-40°C to +70°C (-40°F to 158°F)

Specifications	
D-10 Dimensions: D-20 Dimensions:	Diameter: 5.8 cm (2.3 in.), Length: 28.2 cm (11.1 in.) Diameter: 5.8 cm (2.3 in.), Length: 53.6 cm (21.1 in.)
Float Requirements:	Low: 3.8 cm (1.5 in.), High: 27.9 cm (11 in.)
Cable:	Belden #88760 or Alpha #55371 3.6m (12 feet) of gas & oil resistant cable to the inline ISIM + 1.3m (4 feet) ISIM tail.
Maximum Wiring Length ¹ :	305 m (1,000 ft.) field wiring
Alarm Threshold Configuration:	Fully Automatic
Diagnostic Reading on sensor setup:	12 to 13 (normal), 3 to 4 (lower float in alarm - raised), 1 to 2 (upper and lower float in alarm - raised)
Multi-Drop Restriction	Maximum points per channel = 12 points, 924B and DMP Probes = 4 points, ISIM Smart Sensors = 1 point Devices can be mixed in any combination to hold a maximum of 12 points on one channel
Connections:	Red = Power, Black = Signal, Shield = Ground

1. This is the maximum length of wire to be used to connect all sensors on one channel. This length includes the wire from the Barrier to each sensor board in the string.

14.6.3 Installation



NOTICE!



Make sure you read and fully understand the warnings and information found in the **Hazardous Areas** section of your console's Installation Guide before you install or do the servicing of this sensor.

CAUTION!

ALWAYS obey Local and National Electrical Codes applicable to the installation location.



Make sure that the cables (gas and oil resistant OPW Fuel Management Systems part # 12-1030) from the field wiring to the controller are in conduit that is dedicated to intrinsically safe wiring.

Use wire-nuts and epoxy-resin seal-packs for field connections (refer to M00-390008 Waterproof Electrical Connections for information).

- This sensor uses ONE Controller Interface I.S. Module position
- Start with the Connections table and "Typical Installation" drawing below.
- Make sure the sump pit or pan is dry.

- Install the sensor so that it touches the bottom of the sump pit or pan.
- Connect the sensor cable to the sensor.
- Connect the sensor wires to the field wires in the junction box. Use the supplied cable gland and silicon wire nuts.
- Seal the electrical connections with the epoxy seal packs (refer to M00-390008 Waterproof Electrical Connections for instructions).
- Install explosion-resistant sealing fittings at both ends of the conduit. Refer to the **Probe-Cable Seal-offs** section of the console's Installation Guide for instructions.

14.6.4 Connections

Sensor Wire Color	12V Smart Sensor Interface Channel
Red	Power
Black (hydrocarbon sensor)	Signal
Shield (or 3rd conductor)	Ground

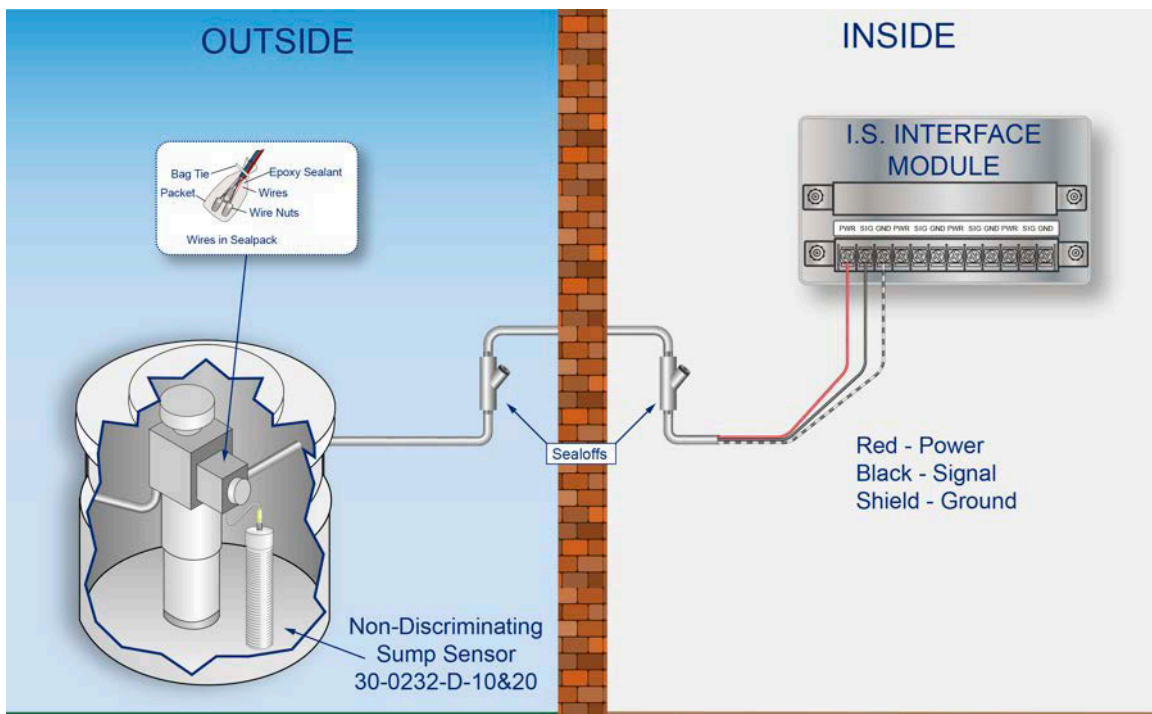

14.6.5 Typical Installation Drawing



14.6.6 Controller Setup

The sensor must be **Auto Detected** on the console. Refer to the M2051 MagLink LX4/LX Plus Configuration Manual, Admin Account > System Settings > Site Info for information for information about *auto-detection*. Alarm thresholds are configured automatically through the *Intelli-sense* mechanism between the sensor and the console.

14.6.7 Float Sensor Test

		CAUTION!
	Use caution to prevent dangerous conditions when you do work in a hazardous area.	
	Make sure that the area has sufficient airflow when you do a test or remove contamination from the sensor. Make sure there are no open flames or hot surfaces near the work area.	

Sensor installed in a normally dry well

- Put the float in the HIGH position. This will cause an alarm condition in the controller.
- Put the float back in the LOW position. Make sure that the controller is not in an alarm condition.

Sensor installed in a normally wet well

- Put the float in the LOW position. This will cause an alarm condition in the controller.
- Put the float back in the HIGH position. Make sure that the controller is not in an alarm condition.

If the controller does not go into an alarm condition, look to see if the thresholds are correctly programmed in the system. Look to see if the float is in the correct position (refer to the applicable instruction above). A sensor or wiring fault will cause a system alarm. Do a continuity test in the wiring and junction boxes. Make sure there is continuity with no short circuits.

14.7 Discriminating Dispenser Sump/STP Sump Sensor

14.7.1 Smart Sensor Equipped with Intellisense™ Technology



Figure 14-6 30-0232-DH-10 & 30-0232-DH-20

14.7.2 Description



IMPORTANT: This float body is the same as the 30-0232-D10 / D20 and 30-0232-D-10B / D-20B. Look at the label to make sure you have the correct sensor for the applicable function.

The primary function of the Discriminating Dispenser Sump/STP Sump Sensor is to sense liquid hydrocarbons and water in sumps, fuel dispenser pans and other locations where there is liquid that could indicate that a leak has occurred. Use the DH-10 on fuel dispenser pans and transition sumps. Use the DH-20 in tank sumps.

The sensor has a strip made of a carbon/polymer material that changes its electrical resistance when it is touched by liquid hydrocarbons.



Figure 14-7 Sensor with Carbon/polymer Strip

Two (2) float switches are used in the body of the sensor to sense low and high liquid levels. If there is a break in the cable it will cause an alarm condition in the system.

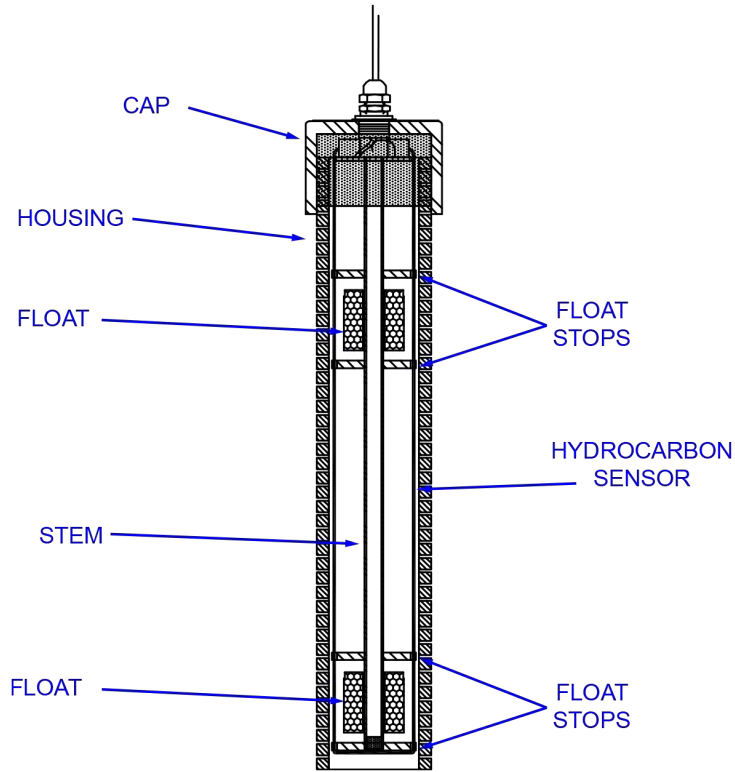



Figure 14-8 Cutaway View of Sensor that Shows Internal Floats

Specifications	
Primary Use(s):	DH-10: Fuel Dispenser Pan/Sump DH-20: STP Sumps
Alternate Uses:	DH-10: STP Sumps DH-20: Fuel Dispenser Pan/Sump
Detects:	Low Liquid, High Liquid, Fuel
Operating Temperature:	-40°C to +70°C (-40°F to 158°F)
DH-10 Dimensions: DH-20 Dimensions:	Diameter: 5.8 cm (2.3 in.), Length: 28.2 cm (11.1 in.) Diameter: 5.8 cm (2.3 in.), Length: 53.6 cm (21.1 in.)
Float Requirements:	Low: 3.8 cm (1.5 in.), High: 27.9 cm (11 in.)
Nominal resistance (uncontaminated)	Less than 5,000 ohms
Nominal resistance (contaminated)	More than 30,000 ohms
Cable:	Belden #88760 or Alpha #55371 3.6 m (12 feet) of gas & oil resistant cable to the inline ISIM + 1.3 m (4 feet) ISIM tail
Maximum Wiring Length ¹ :	305 m (1,000 ft.) field wiring
Alarm Threshold Configuration:	Fully Automatic
Diagnostic Reading on sensor setup:	

Specifications	
Clean Carbon/polymer (no Hydrocarbon)	12 to 13 (normal), 3 to 4 (lower float in alarm - raised), 1 to 2 (upper and lower float in alarm - raised)
Belcor Active (Hydrocarbon present)	3.5 to 3.7 (normal), 1.8 to 2.0 (lower float in alarm - raised), 1.2 to 1.4 (upper and lower float in alarm - raised)
Multi-Drop Restriction	Maximum points per channel = 12 points 924B and DMP Probes = 4 points ISIM Smart Sensors = 1 point Devices can be mixed in any combination to hold a maximum of 12 points on one channel
Connections:	Red = Power, Black = Signal, Shield = Ground

1. This is the maximum length of wire to be used to connect all sensors on one channel. This length includes the wire from the barrier to each sensor board in the string.

14.7.3 Installation



NOTICE!



Make sure you read and fully understand the warnings and information found in the **Hazardous Areas** section of your console's Installation Guide before you install or do the servicing of this sensor.

CAUTION!

ALWAYS obey Local and National Electrical Codes applicable to the installation location.



Make sure that the cables (gas and oil resistant OPW Fuel Management Systems part # 12-1030) from the field wiring to the controller are in conduit that is dedicated to intrinsically safe wiring.

Use wire-nuts and epoxy-resin seal-packs for field connections (refer to M00-390008 Waterproof Electrical Connections for information).

- This sensor uses ONE Controller Interface I.S. Module position
- Start with the Connections table and "Typical Installation" drawing below.
- Make sure the sump pit or pan is dry.
- Install the sensor so that it touches the bottom of the sump pit or pan.
- Connect the sensor cable to the sensor.

- Connect the sensor wires to the field wires in the junction box. Use the supplied cable gland and silicon wire nuts.
- For North American installations, seal the electrical connections with the epoxy seal packs (refer to M00-390008 Waterproof Electrical Connections for instructions).
- Install explosion-resistant sealing fittings at both ends of the conduit. Refer to the **Probe-Cable Seal-offs** section of the console's Installation Guide for instructions.

14.7.4 Connections

Sensor Wire Color	12V Smart Sensor Interface Channel
Red	Power
Black (hydrocarbon sensor)	Signal
Shield (or 3rd conductor)	Ground

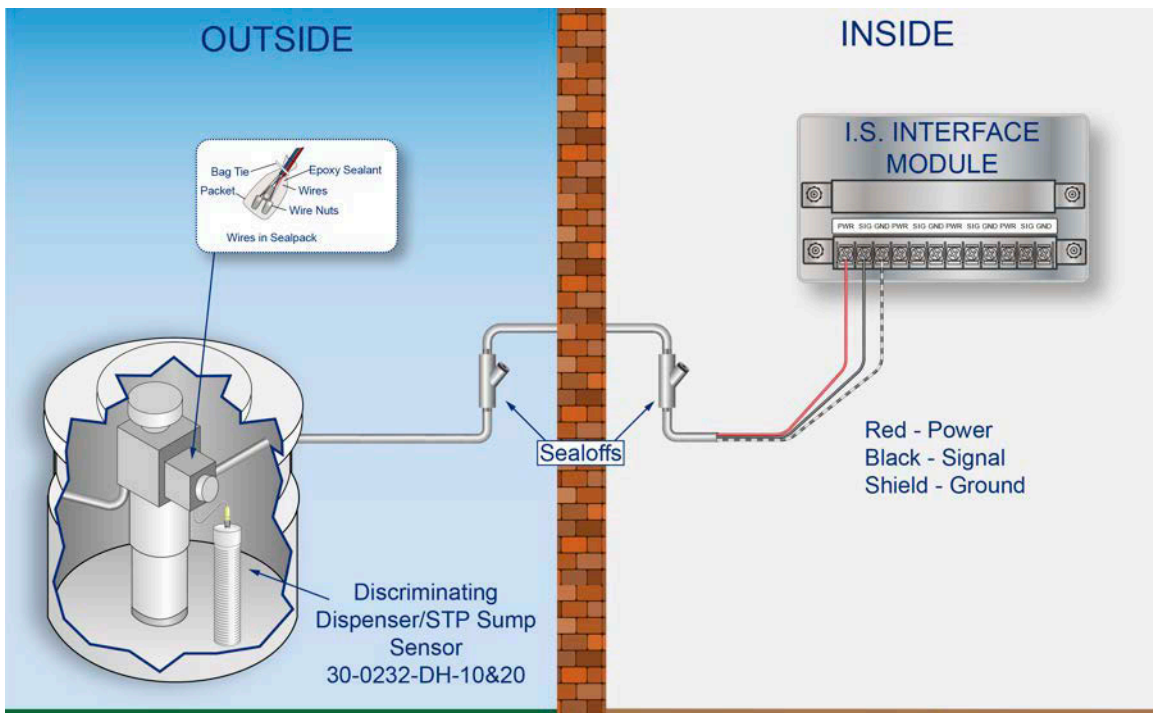

14.7.5 Typical Installation Drawing



14.7.6 Controller Setup

The sensor must be **Auto Detected** on the console. Refer to the M2051 MagLink LX4/LX Plus Configuration Manual, Admin Account > System Settings > Site Info for information for information about *auto-detection*. Alarm thresholds are configured automatically through the *Intelli-sense* mechanism between the sensor and the console.

14.7.7 Float Sensor Test

 CAUTION!	
	<p>Use caution to prevent dangerous conditions when you do work in a hazardous area.</p> <p>Make sure that the area has sufficient airflow when you do a test or remove contamination from the sensor. Make sure there are no open flames or hot surfaces near the work area.</p>

Sensor installed in a normally dry well

- Put the float in the HIGH position. This will cause an alarm condition in the controller.
- Put the float back in the LOW position. Make sure that the controller is not in an alarm condition.

Sensor installed in a normally wet well

- Put the float in the LOW position. This will cause an alarm condition in the controller.
- Put the float back in the HIGH position. Make sure that the controller is not in an alarm condition.

If the controller does not sense the alarm conditions simulated by these tests, look to see if the thresholds and alarms are correctly programmed in the system. Look to see if the float is in the correct position (refer to the applicable instruction above). A sensor or wiring fault will cause a system alarm. Do a continuity test in the wiring and junction boxes. Make sure there is continuity with no short circuits.

14.7.8 Hydrocarbon Sensor - Functional Test and Remove Contamination



IMPORTANT: *It is recommended to only do the procedures below when it becomes necessary and only as a last alternative. These procedures can cause a decrease in the original electrical resistance of the polymer. If possible, speak with a certified OPW-FMS technician before you do these procedures.*

 NOTICE!	
	<p>Do not use fuel (gasoline, diesel etc.) to test or clean the sensor!</p> <p>Once the carbon/polymer material has touched liquid hydrocarbon, it is possible that the sensor will not return to its initial electrical resistance. This can have an unwanted effect on its operation. Replace the sensor if necessary. If you do not obey this instruction it can void your warranty.</p>

Functional Test - Hydrocarbon Liquid Sensor of the Device

- Put the polymer fully into *Mineral Spirits* and wait approximately 10 minutes.
- Remove the sensor and let it hang to air dry for another 10 minutes.
- The test is satisfactory if an alarm condition or other event related to the hydrocarbon part of the sensor occurs. If the test results are unsatisfactory, replace the sensor.

Functional Test - Water Sensor of the Device

- Put the end of the sensor fully into *TAP water* for at least two (2) minutes.
- The test is satisfactory if an alarm condition or other event related to the water sensor of the device occurs.

Clean the Hydrocarbon Sensor of the Device

- Make sure the sensor is disconnected.
- Put the contaminated portion of the sensor fully into *Denatured Alcohol* for one (1) hour.
- Flush the sensor with water to remove all remaining contamination.
- Let the sensor dry in the air for one (1) hour.
- Reconnect the sensor.



NOTE: *If the sensor does not return to near its original resistance after you do a functional test or contamination has been removed, it is recommended to replace the sensor.*

14.8 Dual Float Brine Sensors

14.8.1 Smart Sensor Equipped with Intellisense™ Technology



Figure 14-9 30-0232-D-10B (for Containment Sump) and 30-0232-D-20B (for Fiberglass Tanks)

14.8.2 Description



IMPORTANT: This float body is the same as the 30-0232-D-10 / D-20 and 30-0232-DH-10 / DH-20 (DH-XX has a carbon-polymer strip in the bottom). Look at the label to make sure you have the correct sensor for the applicable function.

The primary function of the Dual Float Brine Sensor is to sense liquid in the brine-filled reservoir of the interstitial area of a doubled-walled tank. Two (2) float switches are used in the body of the sensor to sense fluid level changes. The device will cause an alarm condition in the system if the fluid level increases or decreases more than the normal constant level in the middle between the upper and lower floats. If there is a break in the cable it will cause an alarm condition in the system.

Since this sensor is not made to sense hydrocarbons it does not use a carbon/polymer strip.



Figure 14-10 No Carbon/Polymer Strip

The bottom float of the brine sensor will stay in the up position in a normal condition. When the sensor is in an alarm condition, the upper float will be in a position to cause the alarm condition or the fluid level has decreased below the bottom float.

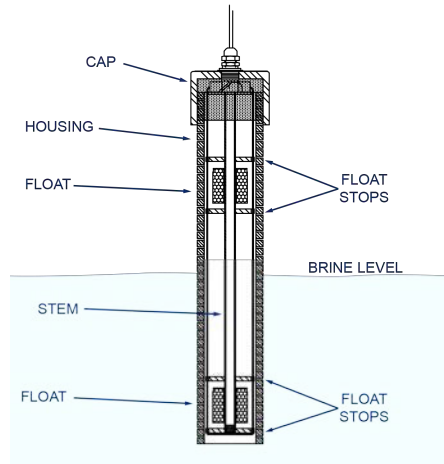



Figure 14-11 Cutaway View of Sensor Showing Internal Floats

Specifications	
Primary Use:	Measure the level of brine solution
Detects:	Low Liquid, High Liquid
Operating Temperature:	-40°C to +70°C (-40°F to 158°F)
D-10B Dimensions: D-20B Dimensions:	Diameter: 5.8 cm (2.3 in.), Length: 28.2 cm (11.1 in.) Diameter: 5.8 cm (2.3 in.), Length: 53.6 cm (21.1 in.)
Float Requirements:	Low: 3.8 cm (1.5 in.), High: 27.9 cm (11 in.)
Cable:	Belden #88760 or Alpha #55371 3.6 m (12 feet) of gas & oil resistant cable to the inline ISIM + 1.3 m (4 feet) ISIM tail
Maximum Wiring Length ¹ :	305 m (1,000 ft.) field wiring
Alarm Threshold Configuration:	Fully Automatic
Diagnostic Reading on sensor setup:	3 to 4 (normal), 12 to 13 (bottom float in alarm - bottom and top floats in the down position), 1 to 2 (upper float in alarm - top and bottom floats in the up position)
Multi-Drop Restriction	Maximum points per channel = 12 points 924B and DMP Probes = 4 points ISIM Smart Sensors = 1 point Devices can be mixed in any combination to hold a maximum of 12 points on one channel
Connections:	Red = Power, Black = Signal, Shield = Ground

1. This is the maximum length of wire to be used to connect all sensors on one channel. This length includes the wire from the Barrier to each sensor board in the string.

14.8.3 Installation



NOTICE!



Make sure you read and fully understand the warnings and information found in the **Hazardous Areas** section of your console's Installation Guide before you install or do the servicing of this sensor.

CAUTION!

ALWAYS obey Local and National Electrical Codes applicable to the installation location.



Make sure that the cables (gas and oil resistant OPW Fuel Management Systems part # 12-1030) from the field wiring to the controller are in conduit that is dedicated to intrinsically safe wiring.

Use wire-nuts and epoxy-resin seal-packs for field connections (refer to M00-390008 Waterproof Electrical Connections for information).

- This sensor uses ONE Controller Interface I.S. Module position
- Start with the Connections table and "Typical Installation" drawing below.
- Connect the sensor cable to the sensor.
- Connect the sensor wires to the field wires in the junction box. Use the supplied cable gland and silicon wire nuts.
- Seal the electrical connections with the epoxy seal packs (refer to M00-390008 Waterproof Electrical Connections for instructions).
- Install explosion-resistant sealing fittings at both ends of the conduit. Refer to the **Probe-Cable Seal-offs** section of the console's Installation Guide for instructions.

14.8.4 Connections

Sensor Wire Color	12V Smart Sensor Interface Channel
Red	Power
Black (hydrocarbon sensor)	Signal
Shield (or 3rd conductor)	Ground

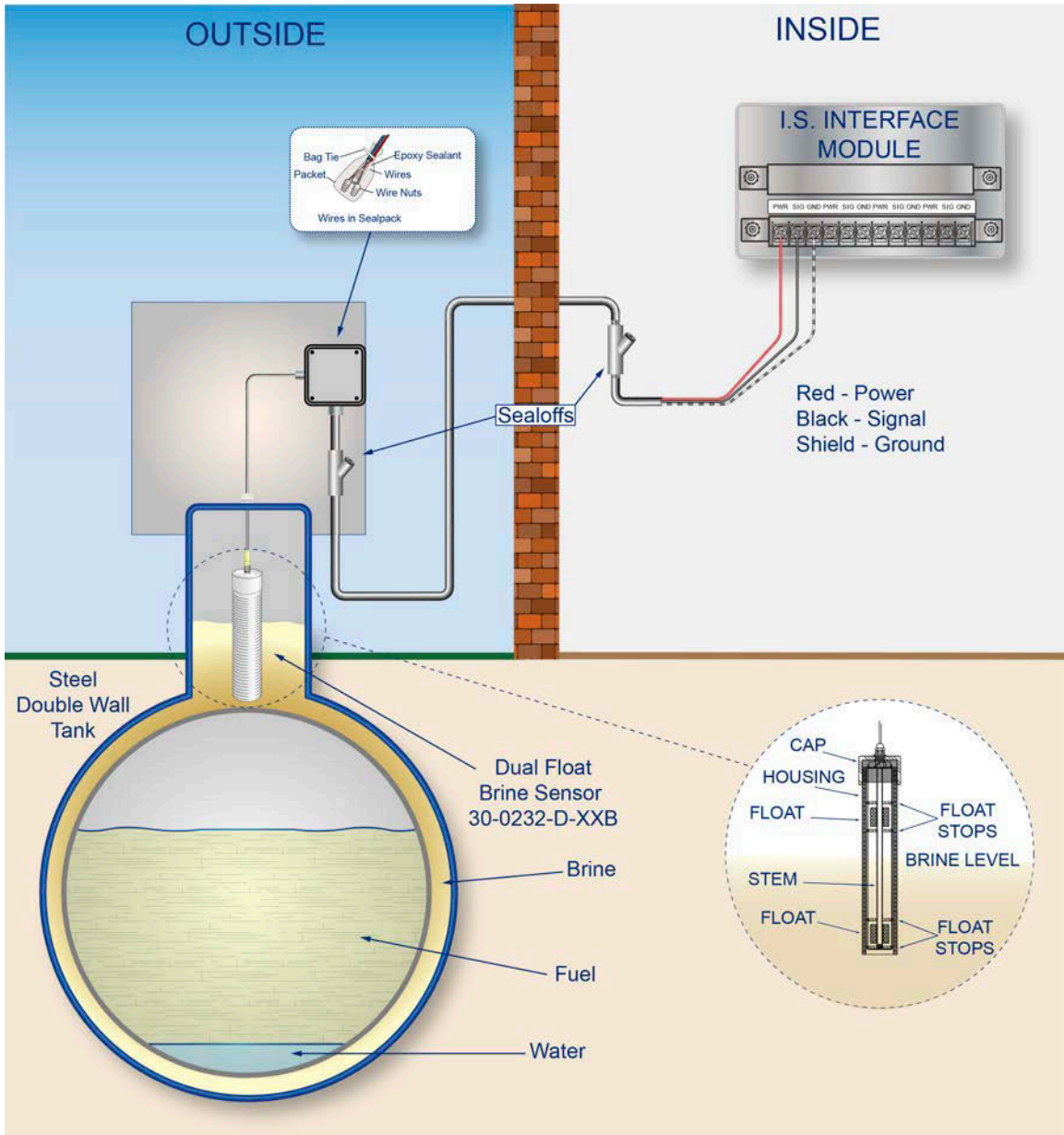

14.8.5 Typical Installation Drawing



14.8.6 Controller Setup

The sensor must be **Auto Detected** on the console. Refer to the M2051 MagLink LX4/LX Plus Configuration Manual, Admin Account > System Settings > Site Info for information for information about *auto-detection*. Alarm thresholds are configured automatically through the *Intelli-sense* mechanism between the sensor and the console.

14.8.7 Float Sensor Test

 CAUTION!	
	Use caution to prevent dangerous conditions when you do work in a hazardous area. Make sure that the area has sufficient airflow when you do a test or remove contamination from the sensor. Make sure there are no open flames or hot surfaces near the work area.

Sensor installed in an interstitial monitoring reservoir

- Put the bottom float in the low position and the top float in the low position. This will cause a low-level alarm condition in the controller.
- Put the bottom float in the high position and the top float in the high position. This will cause a high-level alarm condition in the controller.
- Put the bottom float in the high position and the top float in the low position. Make sure that the controller is not in an alarm condition.

If the controller does not go into an alarm condition, look to see if the thresholds are correctly programmed in the system. Look to see if the float is in the correct position (refer to the applicable instruction above). A sensor or wiring fault will cause a system alarm. Do a continuity test in the wiring and junction boxes. Make sure there is continuity with no short circuits.

14.9 Interstitial Hydrocarbon Liquid Sensor with Water Indicator

14.9.1 Smart Sensor Equipped with Intellisense™ Technology

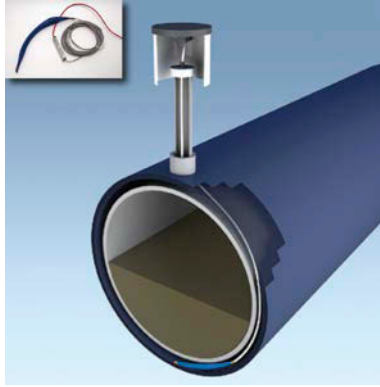

Figure 14-12 30-0234-HW-01

14.9.2 Description

The primary function of the Interstitial Hydrocarbon Liquid with Water Indicator Sensor is to sense liquid hydrocarbons and water in the interstitial area of a double-walled tank. The sensor has a carbon/polymer material that changes its resistance when it is touched by liquid hydrocarbons. The sensor also has a conductive strip to sense water. This lets the sensor tell the difference between hydrocarbon liquid and water. If there is a break in the cable it will cause an alarm condition in the system.

Specifications	
Operating Temperature:	-40°C to +70°C (-40°F to 158°F)
Dimensions:	Length: 35 cm (13.8 in.), Width: 2.5 cm (1.0 in.)
Nominal resistance (uncontaminated)	Less than 3,000 ohms per foot
Nominal resistance (contaminated)	More than 10,000 ohms
Cable:	Belden #88760 or Alpha #55371
Maximum Wiring Length ¹ :	1,000' (305 m) field wiring
Multi-Drop Restriction	Maximum points per channel = 12 points, 924B and DMP Probes = 4 points, ISIM Smart Sensors = 1 point Devices can be mixed in any combination to hold a maximum of 12 points on one channel
Connections:	Red = Power, Black = Signal, Shield: = Ground

1. This is the maximum length of wire to be used to connect all sensors on one channel. This length includes the wire from the Barrier to each sensor board in the string.

14.9.3 Installation



NOTICE!



Make sure you read and fully understand the warnings and information found in the **Hazardous Areas** section of your console's Installation Guide before you install or do the servicing of this sensor.

CAUTION!

ALWAYS obey Local and National Electrical Codes applicable to the installation location.



Make sure that the cables (gas and oil resistant OPW Fuel Management Systems part # 12-1030) from the field wiring to the controller are in conduit that is dedicated to intrinsically safe wiring.

Use wire-nuts and epoxy-resin seal-packs for field connections (refer to M00-390008 Waterproof Electrical Connections for information).



REMINDER: *Hydrocarbons float on water. If the sensor is put fully in water, the polymer will not sense hydrocarbon liquid.*

- This sensor uses ONE Controller Interface I.S. Module position
- Start with the Connections table and "Typical Installation" drawing below.
- Connect the sensor cable to the sensor.
- Connect the sensor wires to the field wires in the junction box. Use the supplied cable gland and silicon wire nuts.
- Seal the electrical connections with the epoxy seal packs (refer to M00-390008 Waterproof Electrical Connections for instructions).
- Install explosion-resistant sealing fittings at both ends of the conduit. Refer to the **Probe-Cable Seal-offs** section of the console's Installation Guide for instructions.

14.9.4 Connections

Sensor Wire Color	12V Smart Sensor Interface Channel
Red	Power
Black	Signal
Shield	Ground

14.9.5 Typical Installation Drawing

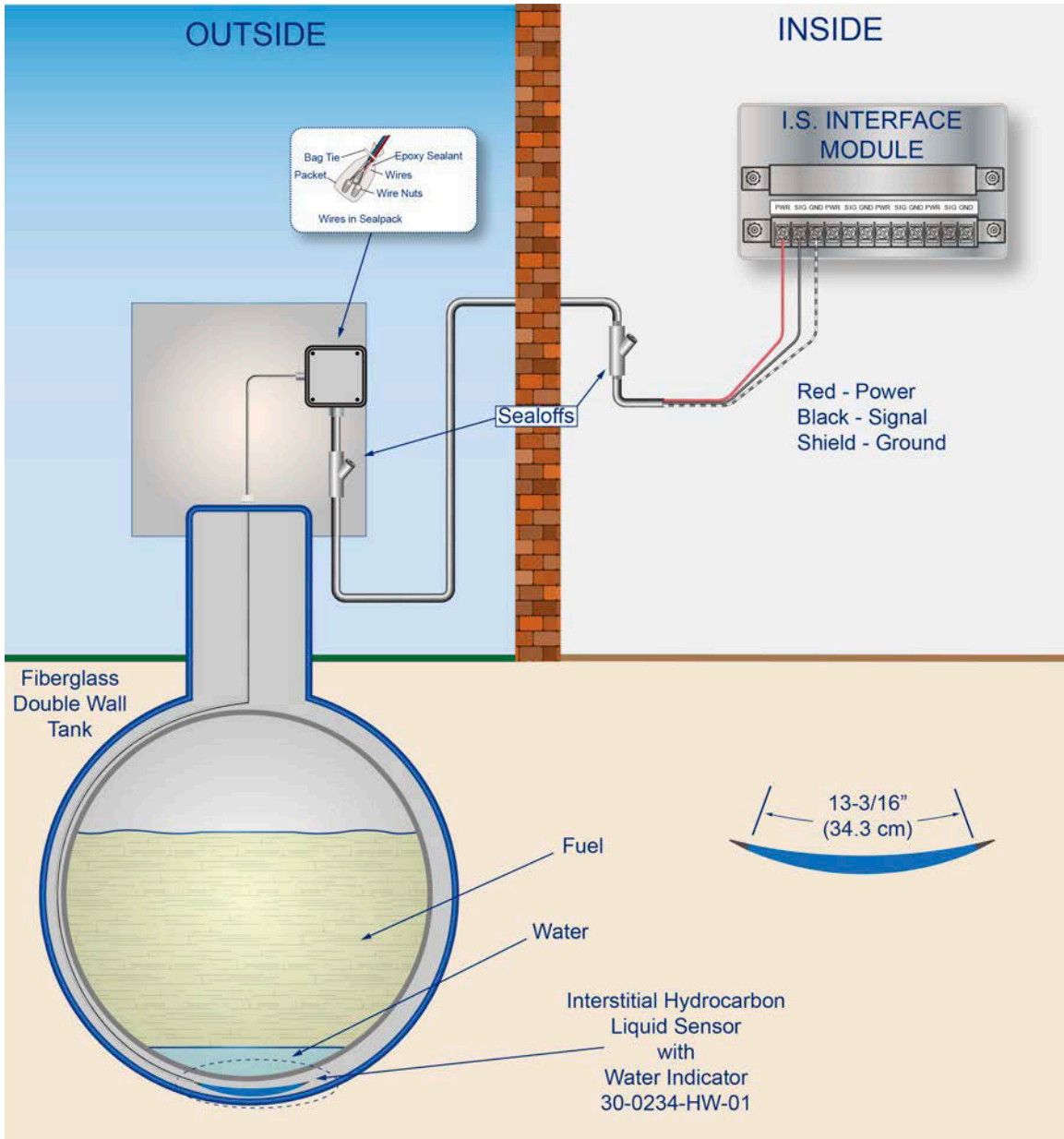

14.9.6 Controller Setup

The sensor must be **Auto Detected** on the console. Refer to the M2051 MagLink LX4/LX Plus Configuration Manual, Admin Account > System Settings > Site Info for information for information about *auto-detection*. Alarm thresholds are configured automatically through the *Intelli-sense* mechanism between the sensor and the console.

14.9.7 Interstitial Hydrocarbon Liquid Sensor with Water Indicator - Functional Test and Remove Contamination

**CAUTION!**

Use caution to prevent dangerous conditions when you do work in a hazardous area.



Make sure that the area has sufficient airflow when you do a test or remove contamination from the sensor. Make sure there are no open flames or hot surfaces near the work area.

**NOTICE!**

Do not use fuel (gasoline, diesel etc.) to test or clean the sensor! Once the carbon/polymer material has touched liquid hydrocarbon, it is possible that the sensor will not return to its initial electrical resistance. This can have an unwanted effect on its operation. Replace the sensor if necessary. If you do not obey this instruction it can void your warranty.

Functional Test - Hydrocarbon Liquid Sensor of the Device

- Put the polymer fully into *Mineral Spirits* and wait approximately 10 minutes.
- Remove the sensor and let it hang to air dry for another 10 minutes.
- The test is satisfactory if an alarm condition or other event related to the hydrocarbon sensor of the device occurs. If the test results are unsatisfactory, replace the sensor.
- Disconnect the Hydrocarbon Sensor from the I.S. terminal strip in the controller. The test is satisfactory if an alarm condition occurs.
- Connect the sensor back to the I.S. terminal strip.
- Short across the power and signal terminals. This test is satisfactory if NO alarm condition occurs.

If the controller does not sense the alarm conditions simulated by these tests, look to see if the thresholds and alarms are correctly programmed in the system. A sensor or wiring fault will cause a system alarm. Do a continuity test in the wiring and junction boxes. Make sure there is continuity with no short circuits.

Functional Test - Water Sensor of the Device

- Put only the end of the sensor into *tap water*. The test is satisfactory if an alarm condition or other event related to the water sensor of the device occurs.
- Disconnect the Water Sensor from the I.S. terminal strip in the controller. The test is satisfactory if NO alarm condition occurs.
- Connect the sensor back to the I.S. terminal strip.
- Short across the power and signal terminals. This test is satisfactory if an alarm condition occurs.

If the controller does not sense the alarm conditions simulated by these tests, look to see if the thresholds and alarms are correctly programmed in the system. A sensor or wiring fault will cause a system alarm. Do a continuity test in the wiring and junction boxes. Make sure there is continuity with no short circuits.

Clean the Hydrocarbon Sensor of the Device

If it is necessary to clean hydrocarbon contamination from the sensor after a test or actual use:

- Make sure the sensor is disconnected.
- Put the dirty part of the sensor fully into *denatured alcohol* for one (1) hour.
- Flush the sensor with water to remove all remaining contamination.
- Let the sensor dry in the air for one (1) hour.
- Reconnect the sensor.



NOTE: *If the sensor does not return to near its original resistance after you do a functional test or contamination has been removed, it is recommended to replace the sensor.*

14.10 Hydrocarbon Liquid Sensor with Water Indicator

14.10.1 Smart Sensor Equipped with Intellisense™ Technology



Figure 14-13 30-0234-HW-06, -15, -20

14.10.2 Description

The primary function of the Hydrocarbon Liquid Sensor with Water Indicator is to monitor dry wells with groundwater tables that can change levels. This sensor uses a carbon/polymer material that changes its resistance when it is touched by liquid hydrocarbons. The device also has a water sensor that has conductive material to sense water. This lets the device tell the difference between hydrocarbon liquid and water.

The sensor can tell the system if there is water in a containment area. It can also tell the system if there are fuel leaks in a containment area. If there is a break in the cable it will cause an alarm condition in the system.

Specifications	
Primary Use:	Monitoring Wells
Detects:	Liquid Hydrocarbons and Water
Operating Temperature:	-40°C to +70°C (-40°F to 158°F)
Dimensions:	Length: 6' (1.9 m), 15' (4.6 m) or 20' (6.1 m) Diameter: 0.7" (1.8 cm)
Nominal resistance (uncontaminated)	Less than 3,000 ohms per foot
Nominal resistance (contaminated)	More than 30,000 ohms
Cable:	Belden #88760 or Alpha #55371
Maximum Wiring Length ¹ :	1,000' (305 m) field wiring
Multi-Drop Restriction	Maximum points per channel = 12 points, 924B and DMP Probes = 4 points, ISIM Smart Sensors = 1 point Devices can be mixed in any combination to hold a maximum of 12 points on one channel
Connections:	Red = Power, Black = Signal, Shield = Ground

1. This is the maximum length of wire to be used to connect all sensors on one channel. This length includes the wire from the Barrier to each sensor board in the string.

14.10.3 Installation



NOTICE!



Make sure you read and fully understand the warnings and information found in the **Hazardous Areas** section of your console's Installation Guide before you install or do the servicing of this sensor.

CAUTION!

ALWAYS obey Local and National Electrical Codes applicable to the installation location.



Make sure that the cables (gas and oil resistant OPW Fuel Management Systems part # 12-1030) from the field wiring to the controller are in conduit that is dedicated to intrinsically safe wiring.

Use wire-nuts and epoxy-resin seal-packs for field connections (refer to M00-390008 Waterproof Electrical Connections for information).



REMINDER: *Hydrocarbons float on water. If the sensor is fully submerged in water, the polymer is unable to detect hydrocarbon liquid.*

- This sensor uses ONE Controller Interface I.S. Module position
- Start with the Connections table and "Typical Installation" drawing below.
- Connect the sensor cable to the sensor.
- Connect the sensor wires to the field wires in the junction box. Use the supplied cable gland and silicon wire nuts.
- Seal the electrical connections with the epoxy seal packs (refer to M00-390008 Waterproof Electrical Connections for instructions).
- Install explosion-resistant sealing fittings at both ends of the conduit. Refer to the **Probe-Cable Seal-offs** section of the console's Installation Guide for instructions.

14.10.4 Connections

Sensor Wire Color	12V Smart Sensor Interface Channel
Red	Power
Black	Signal
Shield	Ground

14.10.5 Typical Installation Drawing

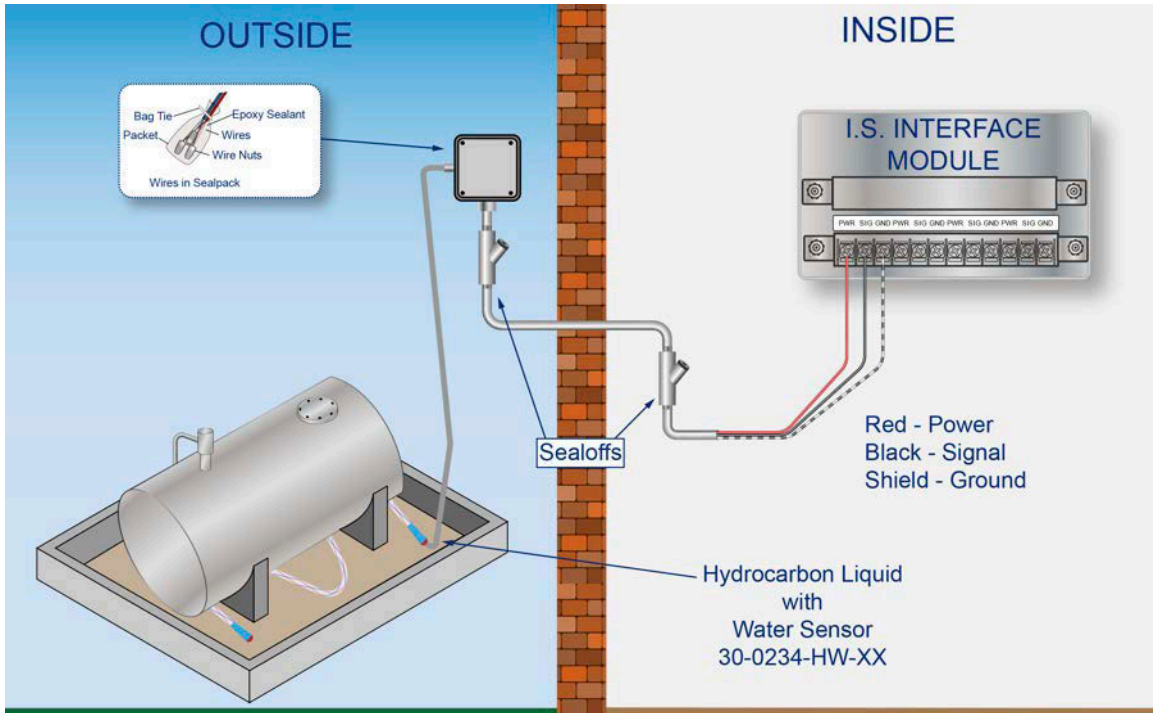



14.10.6 Controller Setup

The sensor must be **Auto Detected** on the console. Refer to the M2051 MagLink LX4/LX Plus Configuration Manual, Admin Account > System Settings > Site Info for information for information about *auto-detection*. Alarm thresholds are configured automatically through the *Intelli-sense* mechanism between the sensor and the console.

14.10.7 Hydrocarbon Liquid/Water Sensor - Functional Test and Remove Contamination



IMPORTANT: *It is recommended to only do the procedures below when it becomes necessary and only as a last alternative. These procedures can cause a decrease in the original electrical resistance of the polymer. If possible, speak with a certified OPW-FMS technician before you do these procedures.*

 CAUTION!	
	Use caution to prevent dangerous conditions when you do work in a hazardous area.
	Make sure that the area has sufficient airflow when you do a test or remove contamination from the sensor. Make sure there are no open flames or hot surfaces near the work area.

 NOTICE!	
	Do not use fuel (gasoline, diesel etc.) to test or clean the sensor! Once the carbon/polymer material has touched liquid hydrocarbon, it is possible that the sensor will not return to its initial electrical resistance. This can have an unwanted effect on its operation. Replace the sensor if necessary. If you do not obey this instruction it can void your warranty.

Functional Test - Hydrocarbon Liquid Sensor of the Device

- Put the polymer fully into *Mineral Spirits* and wait approximately 10 minutes.
- Remove the sensor and let it hang to air dry for another 10 minutes.
- The test is satisfactory if an alarm condition or other event related to the hydrocarbon sensor of the device occurs. If the test results are unsatisfactory, replace the sensor.
- Disconnect the Hydrocarbon Sensor from the I.S. terminal strip in the controller. The test is satisfactory if an alarm condition occurs.
- Connect the sensor back to the I.S. terminal strip.
- Short across the power and signal terminals. This test is satisfactory if NO alarm condition occurs.

If the controller does not sense the alarm conditions simulated by these tests, look to see if the thresholds and alarms are correctly programmed in the system. A sensor or wiring fault will cause a system alarm. Do a continuity test in the wiring and junction boxes. Make sure there is continuity with no short circuits.

Functional Test - Water Sensor of the Device

- Put only the end of the sensor into *tap water*. The test is satisfactory if an alarm condition or other event related to the water sensor of the device occurs.
- Disconnect the Water Sensor from the I.S. terminal strip in the controller. The test is satisfactory if NO alarm condition occurs.
- Connect the sensor back to the I.S. terminal strip.
- Short across the power and signal terminals. This test is satisfactory if an alarm condition occurs.

If the controller does not sense the alarm conditions simulated by these tests, look to see if the thresholds and alarms are correctly programmed in the system. A sensor or wiring fault will cause a system alarm. Do a continuity test in the wiring and junction boxes. Make sure there is continuity with no short circuits.



IMPORTANT: During a Functional Test, liquid can collect inside the shrink tubing (see the image below). This can cause an unusually long time for the sensor to dry.

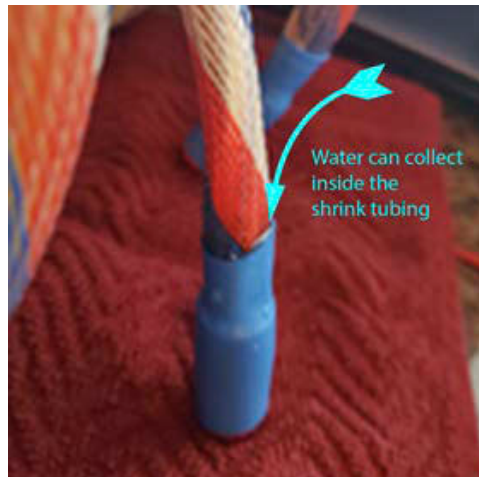



TIP: It is recommended to first pat the sensor dry with a soft, clean cloth. Then, fold the sensor over and hold it in place with a zip-tie to let any remaining liquid drip out of the sensor (see the image below). These steps can help reduce the drying time so the alarm condition can be cleared from 30-45 minutes to 2-10 minutes.



Clean the Hydrocarbon Sensor of the Device

If it is necessary to clean hydrocarbon contamination from the sensor after a test or actual use:

- Make sure the sensor is disconnected.
- Put the dirty part of the sensor fully into *denatured alcohol* for one (1) hour.
- Flush the sensor with water to remove all remaining contamination.
- Let the sensor dry in the air for one (1) hour.
- Reconnect the sensor.



NOTE: If the sensor does not return to near its original resistance after you do a functional test or contamination has been removed, it is recommended to replace the sensor.

14.11 Hydrocarbon Vapor Sensor

14.11.1 Smart Sensor Equipped with Intellisense™ Technology



Figure 14-14 30-0235-V

14.11.2 Description

The primary function of the Hydrocarbon Vapor Sensor is to sense hydrocarbon vapors in monitoring wells and the interstitial areas of a double-walled tank. These vapors could indicate a possibly dangerous leak that could lead to safety and environmental problems. The sensor is made from a long-life resistive element that will increase in resistance when there are hydrocarbon vapors in the closed space where the device is installed. The sensor will return to normal resistance when hydrocarbon vapors are gone. If there is a break in the cable it will cause an alarm condition in the system.

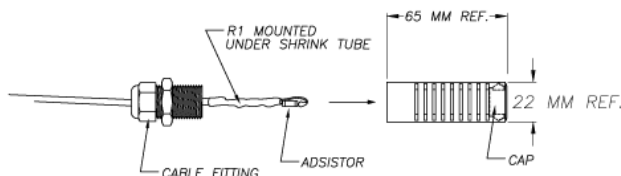



Specifications	
Primary Use:	Monitoring wells
Alternate Use(s):	Interstitial areas of a double-walled tank
Detects:	Hydrocarbon vapor
Operating Temperature:	-40°C to +70°C (-40°F to 158°F)
Dimensions:	Length: 8.9 cm (3.5"), Diameter: 2.3 cm (0.9")
Nominal resistance (uncontaminated)	Less than 5,000 ohms
Nominal resistance (contaminated)	More than 10,000 ohms

Specifications	
Cable:	Belden #88760 or Alpha #55371 3.6m (12 feet) of gas & oil resistant cable to the inline ISIM + 1.3m (4 feet) ISIM tail.
Maximum Wiring Length ¹ :	305 m (1,000 ft.) field wiring
Alarm Threshold Configuration:	Fully Automatic
Diagnostic Reading on Sensor Setup:	0 to 1 (normal) above 5 (in-alarm)
Multi-Drop Restriction	Maximum points per channel = 12 points 924B and DMP Probes = 4 points ISIM Smart Sensors = 1 point Devices can be mixed in any combination to hold a maximum of 12 points on one channel
Connections:	Red = Power, Black = Signal, Shield = Ground

1. This is the maximum length of wire to be used to connect all sensors on one channel. This length includes the wire from the Barrier to each sensor board in the string.

14.11.3 Installation



NOTICE!



Make sure you read and fully understand the warnings and information found in the **Hazardous Areas** section of your console's Installation Guide before you install or do the servicing of this sensor.



CAUTION!

ALWAYS obey Local and National Electrical Codes applicable to the installation location.



Make sure that the cables (gas and oil resistant OPW Fuel Management Systems part # 12-1030) from the field wiring to the controller are in conduit that is dedicated to intrinsically safe wiring.

Use wire-nuts and epoxy-resin seal-packs for field connections (refer to M00-390008 Waterproof Electrical Connections for information).

 **NOTE:** *The device will NOT sense hydrocarbon vapor if it is fully in water.*

- This sensor uses ONE Controller Interface I.S. Module position
- Start with the Connections table and "Typical Installation" drawing below.

- Do a check to make sure there are no hydrocarbon vapors before you install this sensor in a Dry Monitoring Well.
- Install the sensor close to the top, above the water level, if applicable (if the sensor is under water it will not operate).
- Connect the sensor cable to the sensor.
- Connect the sensor wires to the field wires in the junction box. Use the supplied cable gland and silicon wire nuts.
- Seal the electrical connections with the epoxy seal packs (refer to M00-390008 Waterproof Electrical Connections for instructions).
- Install explosion-resistant sealing fittings at both ends of the conduit. Refer to the **Probe-Cable Seal-offs** section of the console's Installation Guide for instructions.

14.11.4 Connections

Sensor Wire Color	12V Smart Sensor Interface Channel
Red	Power
Black (hydrocarbon sensor)	Signal
Shield (or 3rd conductor)	Ground

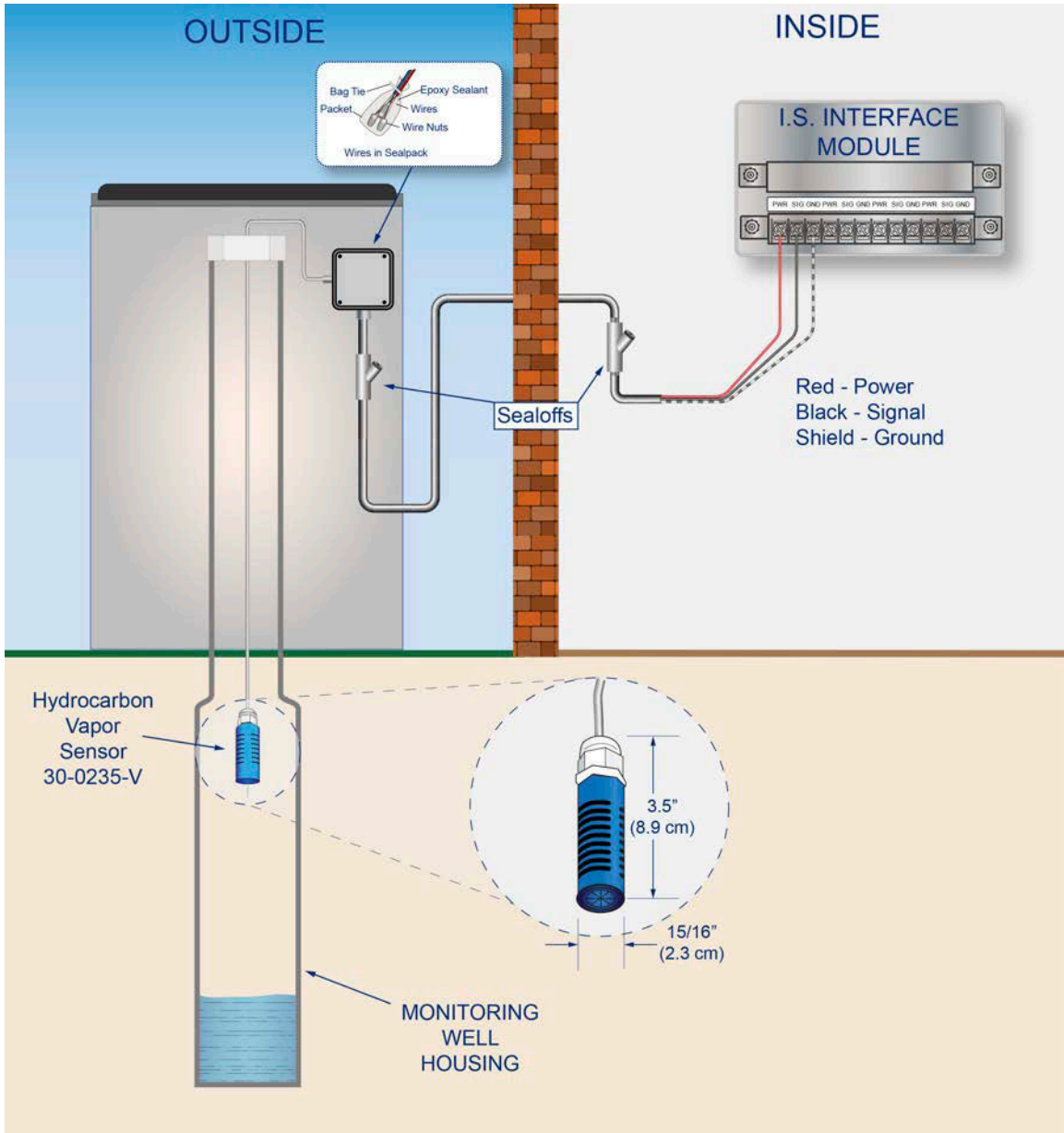

14.11.5 Typical Installation Drawing



14.11.6 Controller Setup

The sensor must be **Auto Detected** on the console. Refer to the M2051 MagLink LX4/LX Plus Configuration Manual, Admin Account > System Settings > Site Info for information for information about *auto-detection*. Alarm thresholds are configured automatically through the *Intelli-sense* mechanism between the sensor and the console.

14.11.7 Test the Hydrocarbon Vapor Sensor

 CAUTION!	
	Use caution to prevent dangerous conditions when you do work in a hazardous area.
	Make sure that the area has sufficient airflow when you do a test or remove contamination from the sensor. Make sure there are no open flames or hot surfaces near the work area.

- Put the sensor in the air space of a container half full with Mineral Spirits.
- Wait approximately 10 minutes. The test is satisfactory if an alarm condition or other event occurs. If the test results are unsatisfactory, replace the sensor.

If the controller does not go into an alarm condition, look to see if the thresholds are correctly programmed in the system. A sensor or wiring fault will cause a system alarm. Do a continuity test in the wiring and junction boxes. Make sure there is continuity with no short circuits.

14.11.8 Clean the Hydrocarbon Vapor Sensor

- Put the sensor fully into Denatured Alcohol for one (1) hour.
- Remove the sensor and let it dry in the air for one (1) hour.
- Reconnect the sensor.



NOTE: *If the sensor does not return to sufficient resistance, replace the sensor if necessary.*

14.12 Discriminating Interstitial Sensor (Optical)

14.12.1 Smart Sensor Equipped with Intellisense™ Technology



Figure 14-15 30-0236-LW

14.12.2 Description

The primary function of the Discriminating Interstitial Optical Liquid Sensor is to monitor the interstitial area of double-walled tanks. This sensor uses a long-life, solid-state optical prism. These sensors can also be used in sumps, fuel dispenser pans and other locations where there is liquid that could indicate that a leak has occurred.

The sensor can tell the difference between water and hydrocarbons and will cause an alarm condition when it senses a liquid. If there is a break in the cable it will cause an alarm condition in the system.

Specifications	
Primary Use:	Liquid detection in the interstitial space of double-walled tanks.
Alternate Use(s):	Fuel Dispenser Pans and STP Sumps
Detects:	Liquids: Hydrocarbon and Water
Operating Temperature:	-40°C to +70°C (-40°F to 158°F)
Dimensions:	0.7 inches (1.8cm) x 2.8 inches (7cm)
Nominal resistance (uncontaminated)	Less than 5,000 ohms
Nominal resistance (contaminated)	More than 30,000 ohms
Cable:	Belden #88760 or Alpha #55371 4.5 m (15 feet) of gas & oil resistant cable to the inline ISIM + 1.3 m (4 feet) ISIM tail
Maximum Wiring Length ¹ :	305 m (1,000 ft.) field wiring
Alarm Threshold Configuration:	Fully Automatic
Diagnostic Reading on Sensor Setup:	0.02 to 0.03 and 0.23 to 0.25 (normal), 0.02 to 0.03 and 0.02 to 0.03 (water alarm), 0.23 to 0.25 and 0.23 to 0.25 (hydrocarbon alarm)

Specifications	
Multi-Drop Restriction	Maximum points per channel = 12 points, 924B and DMP Probes = 4 points, ISIM Smart Sensors = 1 point Devices can be mixed in any combination to hold a maximum of 12 points on one channel
Connections:	Red = Power, Black = Signal, Shield = Ground

1. This is the maximum length of wire to be used to connect all sensors on one channel. This length includes the wire from the Barrier to each sensor board in the string.

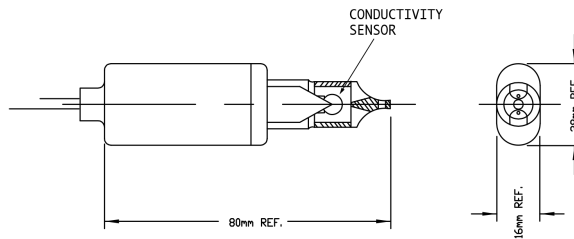

Figure 14-16 30-0236-LW Dimensions

14.12.3 Installation

NOTICE!

Make sure you read and fully understand the warnings and information found in the **Hazardous Areas** section of your console's Installation Guide before you install or do the servicing of this sensor.

CAUTION!

ALWAYS obey Local and National Electrical Codes applicable to the installation location.

Make sure that the cables (gas and oil resistant OPW Fuel Management Systems part # 12-1030) from the field wiring to the controller are in conduit that is dedicated to intrinsically safe wiring.

Use wire-nuts and epoxy-resin seal-packs for field connections (refer to M00-390008 Waterproof Electrical Connections for information).

- This sensor uses ONE Controller Interface I.S. Module position
- Start with the Connections table and "Typical Installation" drawing below.
- Measure the length of the circular space in the monitoring pipe from top to bottom and subtract 1.3 cm (0.5 in.) for a total measurement to be used for the sensor installation.

- Measure the calculated length from the sensor tip along the sensor cable and identify it with tape or a marker.
- Put the sensor and wire through the monitoring opening until the mark is level with the top of the opening.



IMPORTANT: To prevent false alarms, the sensor must not touch the bottom of the monitoring tube

- Connect the sensor wires to the field wires in the junction box. Use the supplied cable gland and silicon wire nuts.
- Seal the electrical connections with the epoxy seal packs (refer to M00-390008 Waterproof Electrical Connections for instructions).
- Install explosion-resistant sealing fittings at both ends of the conduit. Refer to the **Probe-Cable Seal-offs** section of the console's Installation Guide for instructions.

14.12.4 Connections

Sensor Wire Color	12V Smart Sensor Interface Channel
Red	Power
Black (hydrocarbon sensor)	Signal
Shield (or 3rd conductor)	Ground

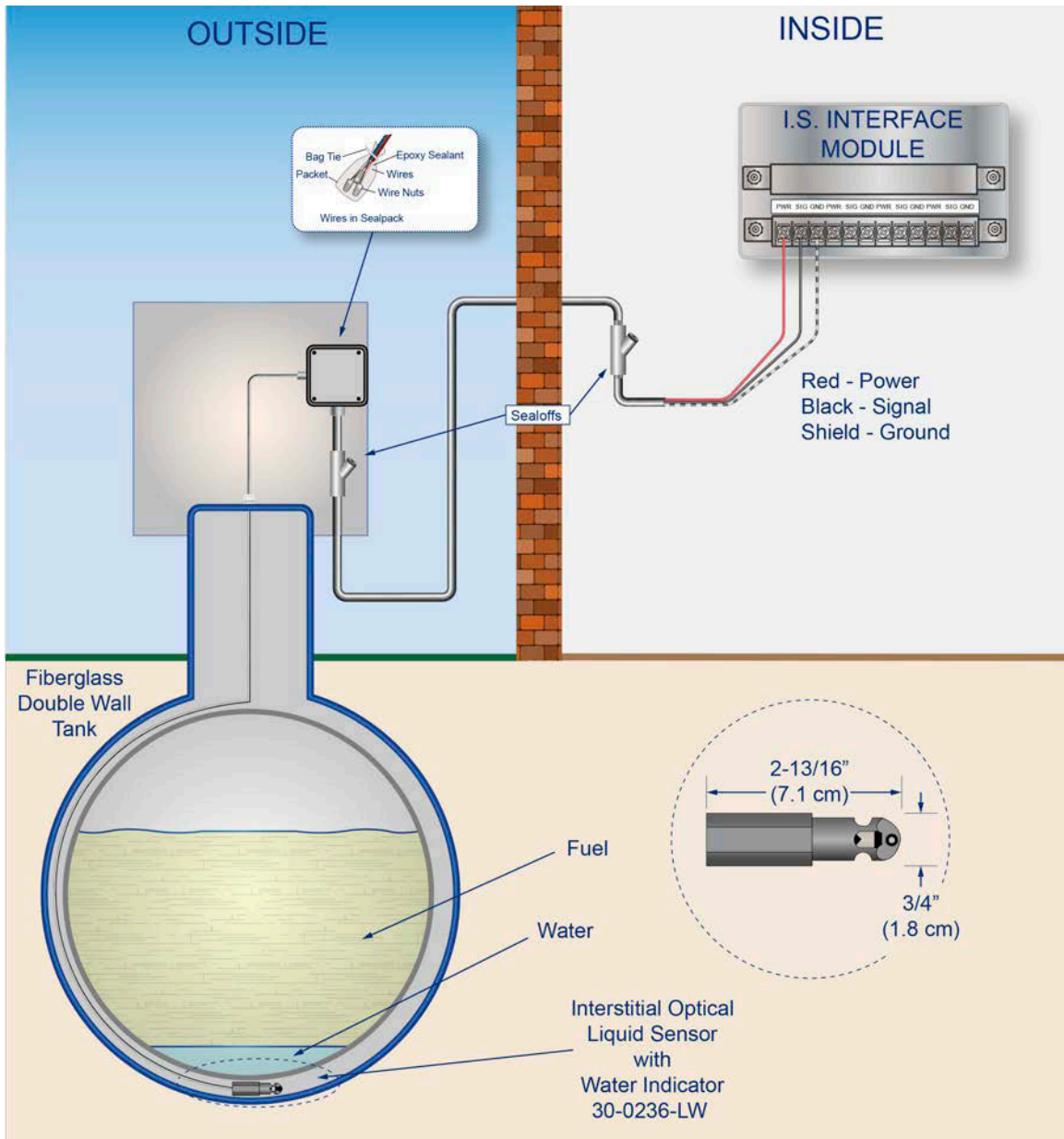

14.12.5 Typical Installation Drawing



14.12.6 Controller Setup

The sensor must be **Auto Detected** on the console. Refer to the M2051 MagLink LX4/LX Plus Configuration Manual, Admin Account > System Settings > Site Info for information for information about *auto-detection*. Alarm thresholds are configured automatically through the *Intelli-sense* mechanism between the sensor and the console.

14.12.7 Test the Optical Sensor

		CAUTION!
	<p>Use caution to prevent dangerous conditions when you do work in a hazardous area.</p>	
	<p>Make sure that the area has sufficient airflow when you do a test or remove contamination from the sensor. Make sure there are no open flames or hot surfaces near the work area.</p>	



IMPORTANT: Make sure to test the Optical Sensor in a dark area. The sensor's optical element is light sensitive. Light can cause the sensor to not test accurately.

Test the Water Sensor of the Device

- Put the sensor fully into water. The test is satisfactory if an alarm condition or other event related to the water part of the sensor occurs.
- Remove the sensor from the water. Make sure that the controller is not in an alarm condition.

Test the Hydrocarbon Liquid Sensor of the Device

- Put the sensor fully into a non-conductive hydrocarbon (or equivalent) liquid. The test is satisfactory if an alarm condition or other event related to the hydrocarbon part of the sensor occurs. If the test results are unsatisfactory, replace the sensor.
- Remove the sensor from the hydrocarbon liquid. Make sure that the controller is not in an alarm condition.

If the controller does not go into an alarm condition, look to see if the thresholds are correctly programmed in the system. A sensor or wiring fault will cause a system alarm. Do a continuity test in the wiring and junction boxes. Make sure there is continuity with no short circuits.



TIP: This sensor can be cleaned with a dry cloth and put back into service again immediately.

15 Probe and Sensor Wiring



Refer to:
 Device Connections to the ISB-1W Internal I.S. Barrier
 for information on the LX Plus "Multi-drop" function.

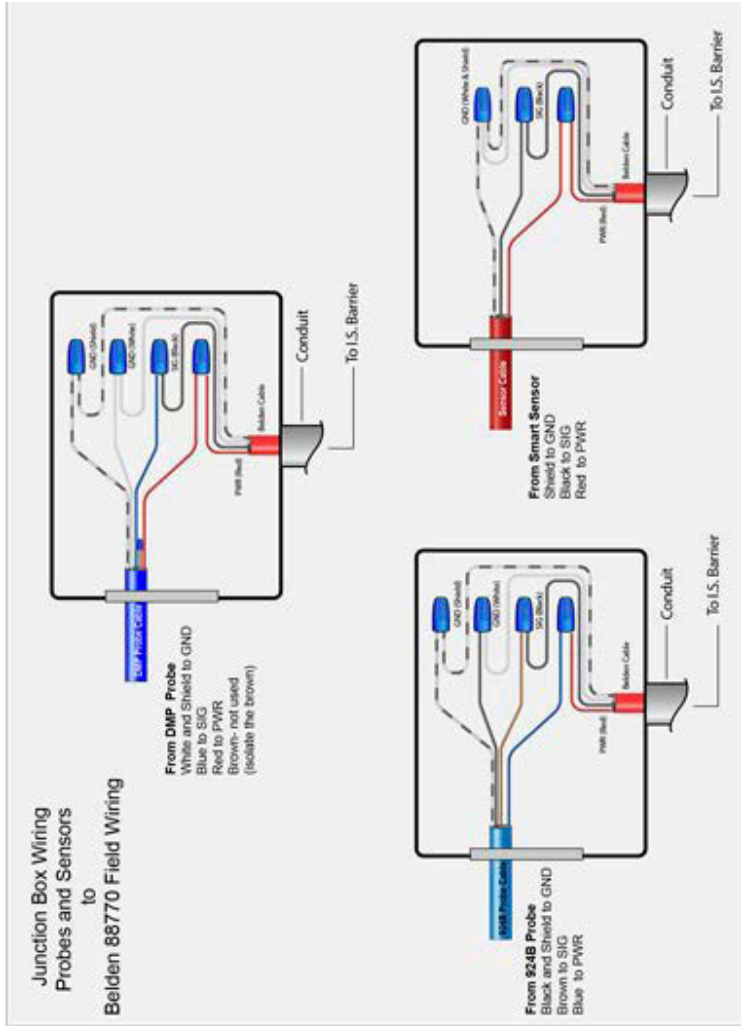
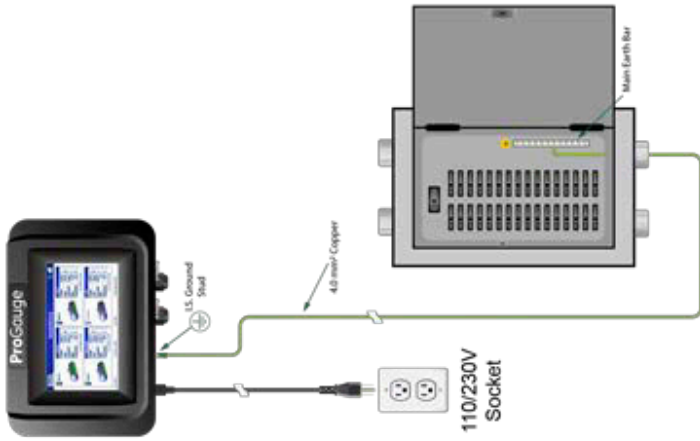
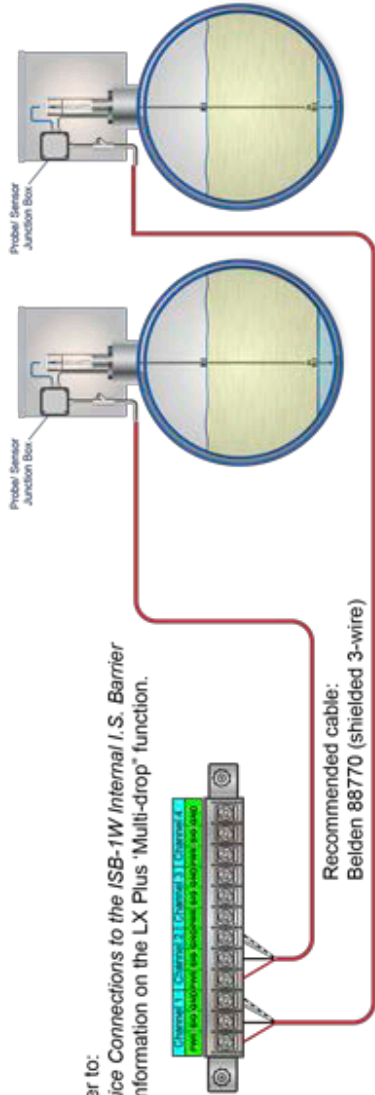



16 PLLD (Pressurized Line Leak Detection) Pressure Sensor Device Installation

The instruction that follows shows the specifications and installation procedure for the PLLD.

16.1 PLLD Specifications

The sensor has a **DIN EN 175301-803 A** wiring connector, where pins 1 and 2 will be used to connect the pressure sensor to the PLLD DAS module. Recommended cable to use is **LiYCY 2 x 0.75 mm²** gas&oil resistant cable.

PLLD Sensor Data		
	<p>Measuring range: 0-6 bar Analogue signal: 4-20 mA Supply voltage: 24 VDC Thread connection: 1/2 "NPT Ingress protection: IP65 Part numbers: 17-PLLD TRASM NPT (ATEX certified) 17-PLLD TRASM NPT-C (UL certified)</p>	 <p>1: +Ve 2: -Ve</p>

The PLLD pressure sensor has a 1/2" NPT male thread. A reducer will be necessary to connect the sensor to the pressure sensor port of a Submersible Turbine Pump (STP).



Figure 16-1 1/2" female NPT-2" male NPT. Stainless steel.

A reducer can be supplied by ProGauge, part number 17-PLLD GUARN.

16.2 PLLD Installation

**WARNING!**

You must obey the safety procedures that follow before you do work to install a PLLD on a Submersible Turbine Pump.

- Make sure you complete an applicable Lock-out Tag-out procedure.
- Remove power from applicable Submersible Turbine Pumps.
- If the STP has a pressure-release screw, use it to relieve pressure in the pump (refer to the STP manufacturer's service documentation).

Refer to the STP manufacturer's documentation to find the correct port to install the PLLD.

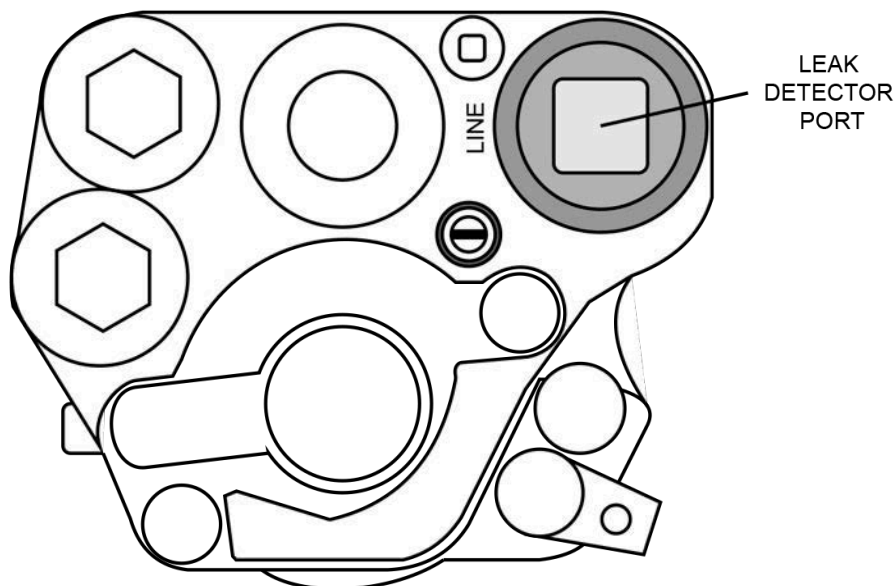

1. Remove all pressure from the product piping.
2. If a leak detector is to be replaced, remove it from the leak detector port. If the PLLD is a new installation, remove the port cover.

**NOTICE!**

Make sure that no debris or scaling enters the system through the leak detector port.

3. Use fuel-absorbent cloths to soak up fuel within the work area. Dry pipe threads fully in the leak detector opening.

4. Seal the Line Port with a plug.



NOTE: Apply fuel-approved thread sealant (not thread tape) to the male threads of the plug.

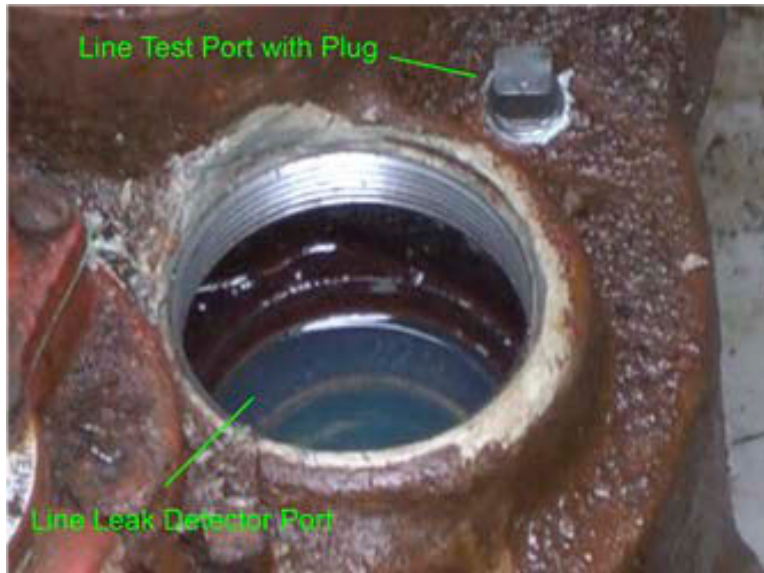

5. Install the 2" adapter in the open submersible pump line leak detector port. Apply fuel-approved thread sealant to the adapter's male threads.



Apply fuel-approved thread sealant to the sensor and adapter male threads.

6. Install the PLLD sensor into the 2" adapter. Apply fuel-approved thread sealant to the male threads of the PLLD and tighten the PLLD by hand.



7. Tighten the sensor on the hex flats with a correct size wrench or an adjustable wrench. Tighten only enough to prevent leakage.



IMPORTANT: Do not over tighten the PLLD or the adapter!

8. Connect the wiring to the sensor terminals as in the illustration below; also see [PLLD Specifications](#) (p. 110).

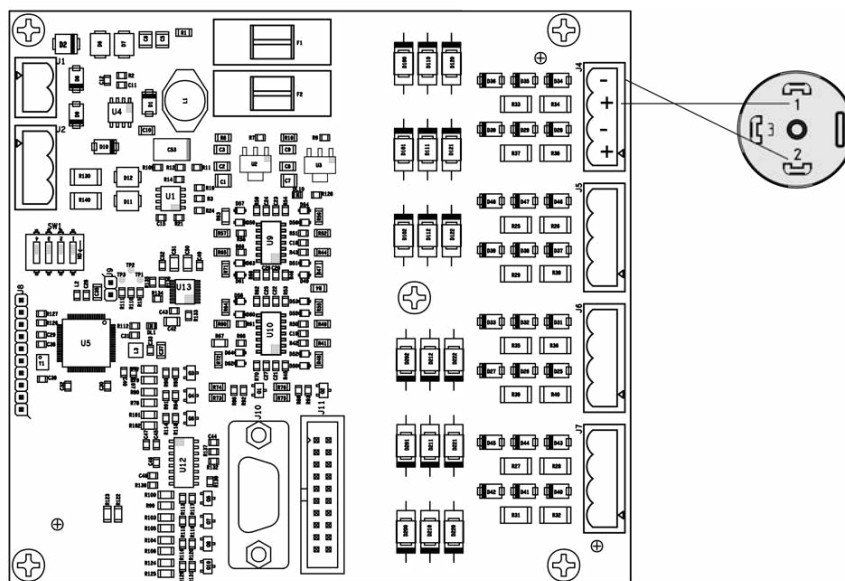

9. The routing of the pressure sensor communications cable will go to a weatherproof junction box within the sump.

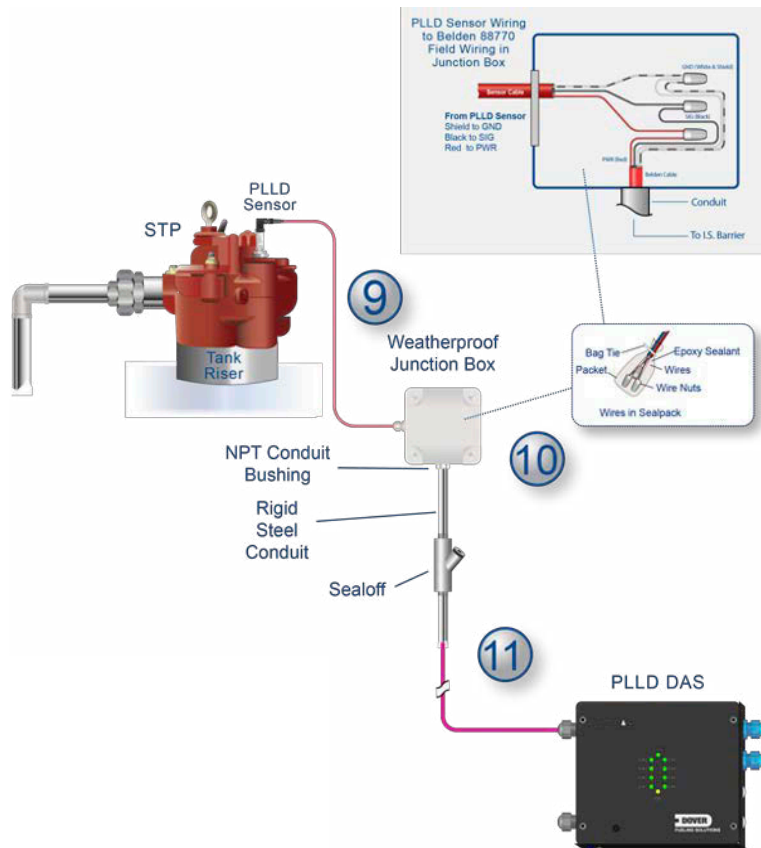

10. After the sensor communications wire has been put into the weatherproof junction box, use wire nuts to connect the sensor cable wires to the field cable.
11. The field cable goes through the dedicated conduit to the PLLD DAS module box inside the store/office.



IMPORTANT: The connections are made below grade and are usually in a manhole or in a single containment sump. It will be necessary for the cable splices to be sealed in a moisture-proof Scotchcast epoxy sealant or equivalent. The epoxy sealpacks are contained in a weatherproof junction box. These seals must be finalized before the system is operational.

For more information on how to install the wiring of the sensor to the field wiring with a Scotchcast epoxy sealpack see [M00-390008 Waterproof ElectricalConnections](#).

12. When all work on the submersible pumps is complete, do the final steps:
- Remove the Lock-out Tag-out.
 - Supply power to the submersible pumps.
 - Do the Line-Leak Detection testing.

17 PLLD-DAS

You can connect up to eight (8) Pressure Line Leak Detection (PLLD) sensors to the Data Acquisition System (PLLD DAS).

17.1 General Warnings

Fully read all instructions in this section before you install or do maintenance on the PLLD DAS

Only approved persons are permitted to install this equipment and configure the console.

The manufacturer is not responsible for operations that are not included in this manual.

The manufacturer is not liable in regards to competent bodies for changes to the equipment and software that are not approved.

In case of failure or defect, refer directly to an authorized service provider or manufacturer.

The manufacturer is not liable for injury and/or damage to persons and/or property and/or pets caused by the failure to obey safety instructions.

All approved personnel must know all safety requirements in this manual, the configuration manual and the user manual.

Refer directly to an approved service provider or manufacturer for questions about the operation of the equipment.



IMPORTANT: You must read and obey all safety instructions in this manual before you use this equipment.



WARNING!

Incorrect use of this equipment that does not agree with the instructions in this manual can cause a risk to safety.



WARNING!



A minimum insulation thickness of 0.25 mm is necessary for all internal wiring of different intrinsically safe circuits. A grounding conductor must be connected between the I.S. ground terminals of the Intrinsic safety barrier in the console and the power distribution panel. This connection must have a cross-sectional area of at least 4 mm² for the added earth connection.

	WARNING!	ADVERTISSEMENT !
	Substitution of components can decrease intrinsic safety.	La substitution des composants peut compromettre la sécurité intrinsèque



READ CAREFULLY: *The control drawing shown in ILL. 14 shall be provided with all devices.*



IMPORTANT: *If a replacement power supply cable is necessary, use an applicable, approved ELBZ/7 type power cord. Do not use another type of power cable.*



NOTE: *The "Control Drawing 220310" shall be given with all devices.*

17.2 General Indications

The PLLD DAS device is shipped in a cardboard box (L 450 x H 300 x D 200 [mm]) and includes:

- PLLD DAS module
- Check-list certifying quality control
- Installation manual
- Safety Instruction (for ATEX installations)
- Control drawing (for UL installations)

Weight of the module with carton box: 5 kg.

The console dimensions are: Width 236 mm (without cable glands), Height 207 mm, Depth 105 mm.

The device is ready to use, configuration is not necessary.

17.3 Installation

17.3.1 Preliminary Warnings

	CAUTION!
The PLLD DAS device is not explosion-proof.	

	CAUTION!
Explosions or fires can cause damage or even death!	

	CAUTION!
Flammable vapors when mixed with air can cause an explosion. Dangerous areas can occur from the presence of gases or vapours.	

	CAUTION!
Do not install the device in a hazardous area.	

	CAUTION!
Failure to connect the Intrinsically Safe Ground connection console to the earth system of the station will compromise the intrinsic safety of the device and may result to high voltage to be sent to the hazardous area thus leading to a potential explosion or fire.	

17.3.2 Installation Location - Attach the Device to a Wall

Select a location for the console installation where weather cannot cause negative effects or damage to the electrical circuits (high and low temperatures, high humidity, direct sunlight etc.).

 **NOTICE!**

Install the device in a place that is protected from moisture, direct sun, and water splashes. The device should be installed indoors in a climate-controlled room.

 **CAUTION!**

The device must be installed in a safe area.

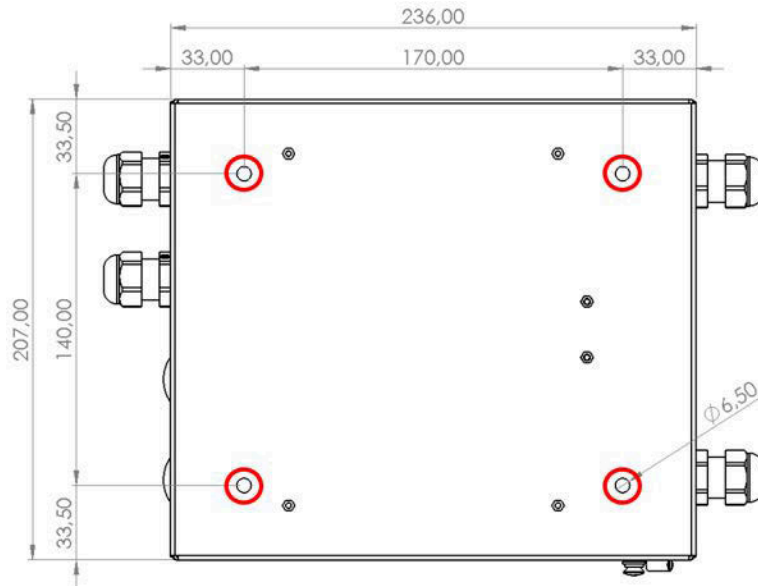

- Remove the top cover of the PLLD DAS device.
- Attach the pack panel of the unit to a wall (it is recommended to use Fischer wall anchors, size 6).
- The image above shows the location of the mounting holes and the dimensions of the device.

17.3.3 Electrical Connections

The instructions that follow show the necessary steps for electrical connection to a 100-220 VAC supply.

1. Put all power switches on the electrical panel to the OFF position.
2. Use applicable connectors to connect the electrical panel and the module.
3. A power supply cable is not supplied with the module. Use ELBZ/7 or equivalent (size 3x18 AWG / 3x0.75 mm²).
4. Make sure the power plug is connected to the ground and has protection against short circuits and power surges.

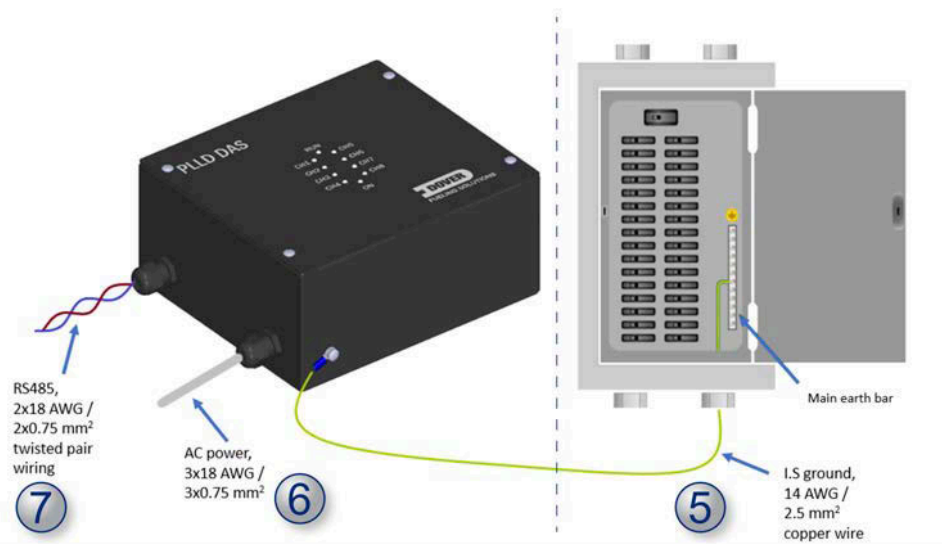

5. Make sure to use a dedicated 14 AWG / 2.5 mm² copper wire to connect the I.S. ground to the station's earth system (see the illustration above).
6. Install a 3x18 AWG / 3x0.75 mm² cable for electrical power (see the illustration above).
7. Install a 2x18 AWG / 2x0.75 mm² twisted-pair cable for the RS485 communication of the module with the ATG console (see the illustration above).
8. Make sure to use applicable conduit.
9. The power cord also functions to remove power from the unit. It must be easy to identify and easy to get access to.



WARNING!



There is high voltage within the module. The electrical connection procedure must only be done by trained and authorized personnel. Obey local regulations for power supply, external switch, circuit-breaker and overcurrent protection device requirements. It is recommended that the switch or circuit-breaker be installed near the equipment.

17.3.4 Module Components and Internal Wiring

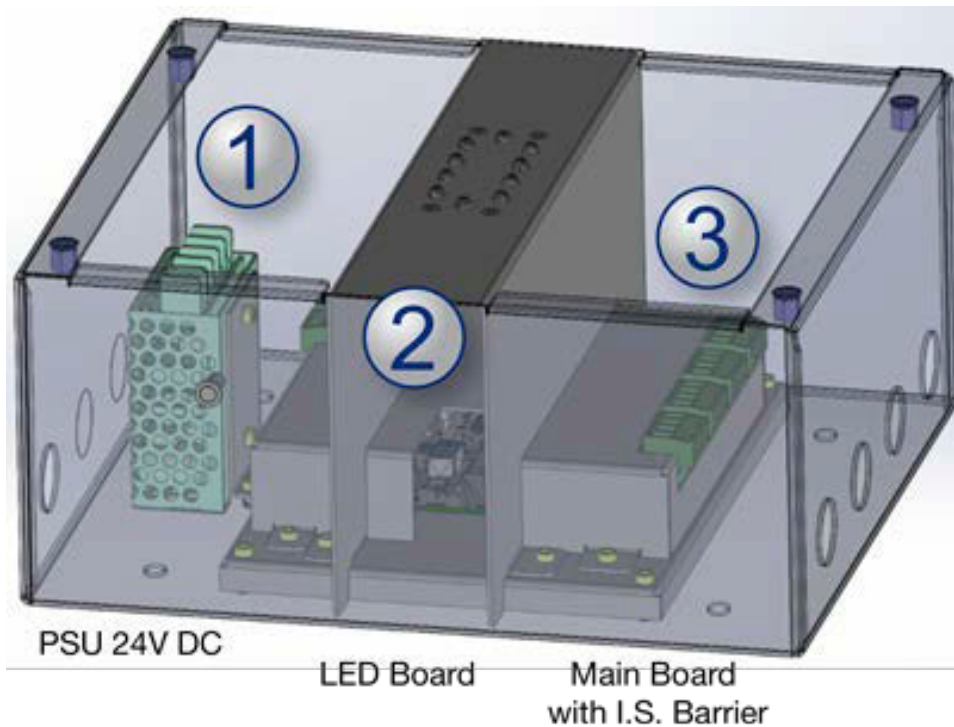
The assemblies shown below can be found at the back panel of the module.



1. Power supply (PSU 24V DC) protection panel.
2. LED board.
3. Mainboard with Intrinsically safe barrier integrated 8 channels 4-20mA.

Exploded View of Components

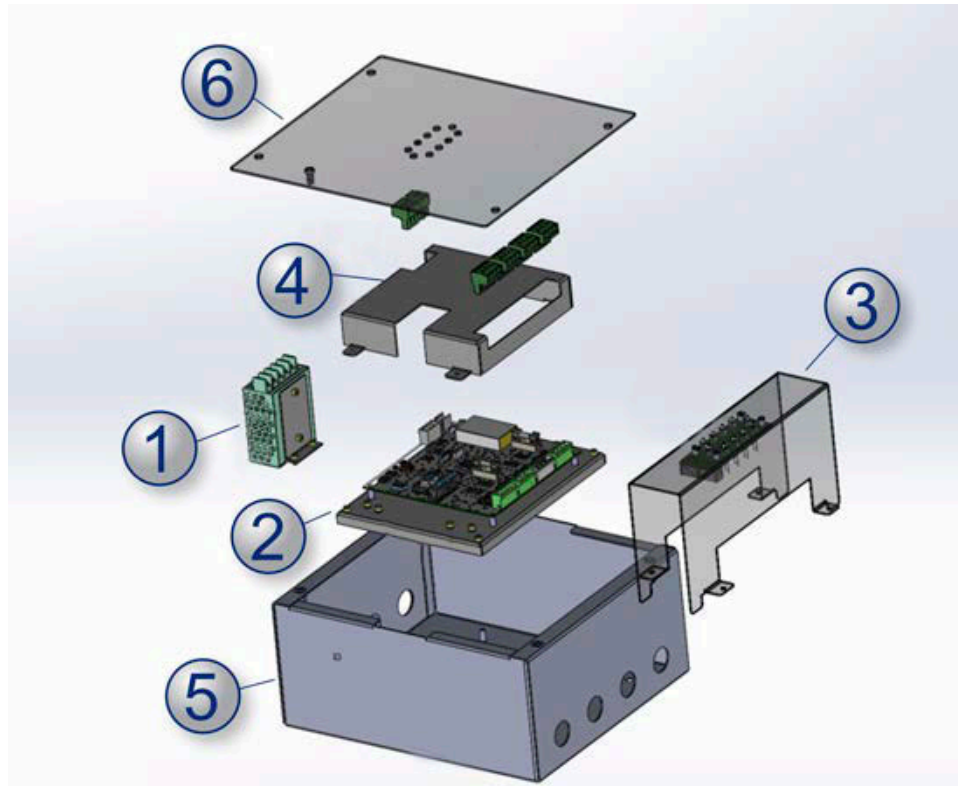

1. Power Supply
2. Main Board
3. LED Board and Separation Wall
4. Main Board Protection Cover
5. Chassis (enclosure)
6. Top Cover

17.3.5 Power and RS485 Connection within the Enclosure

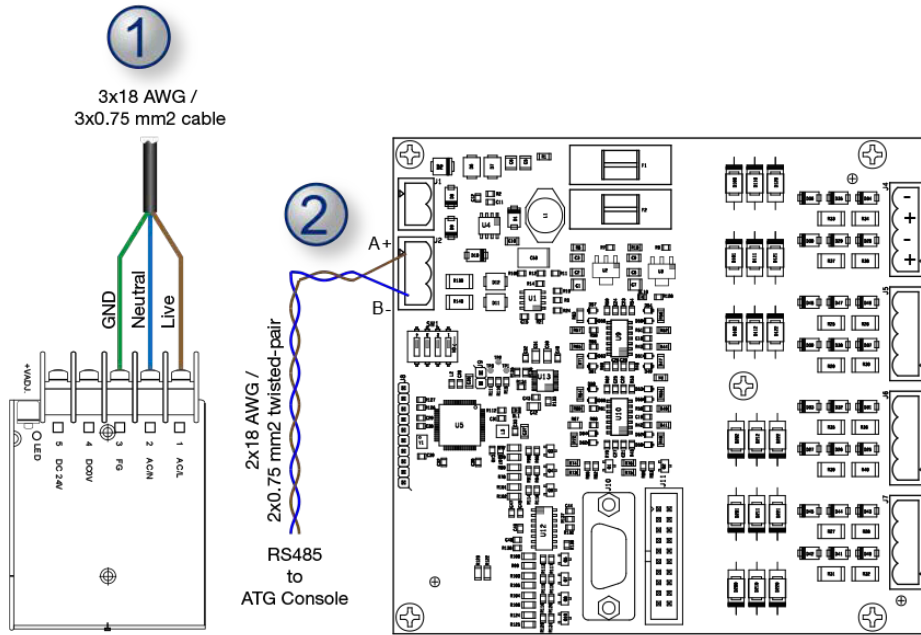

1. Connect a 3x18 AWG / 3x0.75 mm2 cable to the power supply terminals.
2. Connect a 2x18 AWG / 2x0.75 mm2 twisted-pair wiring to the RS485 connector for the RS485 communication of the module with the ATG console.



NOTE: The 24V DC wiring between the power supply and the main board are pre-installed in the factory.

17.3.6 PLLD Sensor Connection to the I.S. Barrier

The PLLD DAS has 8 channels where certified pressure sensors can be connected to through current loop. One pressure sensor can connect to each channel.

There are no serviceable components within the barrier. If a channel becomes defective, it can no longer be used. However, the remaining channels can be used.

The PLLD DAS barrier is powered by the 24V DC power supply which also supplies the voltage to the current loop.

For the current loop wiring, use 2x18 AWG / 2x0.75 mm², gas & oil resistant cabling.

New style PLLD sensor with cable pigtail

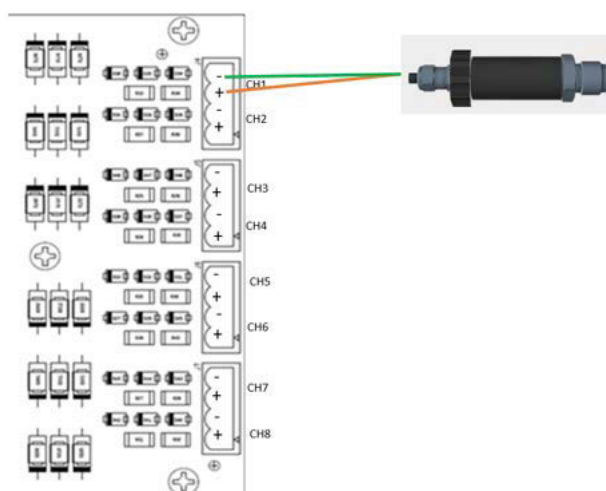

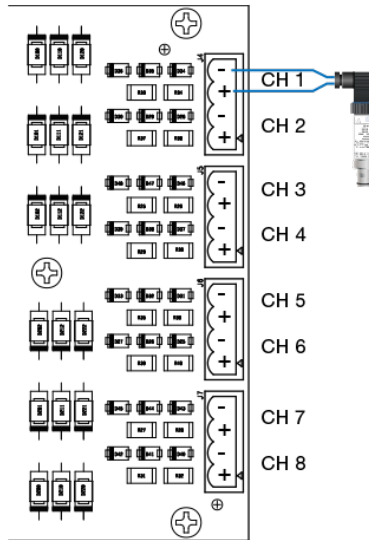

The sensor comes complete with a pigtail cable: The brown cable connects to the “+ve” slot of the channel and the green cable connects to the “-ve” slot channel. Recommended cable to use for the home run is **LiYCY 2 x 0.75 mm²** gas & oil resistant cable.

Older style PLLD sensor with angular connection



The older style PLLD sensor has a **DIN EN 175301-803 A** wiring connector, where pins 1 and 2 will be used to connect the pressure sensor to the PLLD DAS module. Recommended cable to use is **LiYCY 2 x 0.75 mm²** gas & oil resistant cable.

PLLD Sensor Data	
	<p>Measuring range: 0-6 bar Analogue signal: 4-20 mA Supply voltage: 24 VDC Thread connection: 1/2 "NPT Ingress protection: IP68 (<i>Older style with angular connector is IP65</i>) Part numbers: 17-PLLD TRASM NPT (ATEX certified) 17-PLLD TRASM NPT-C (UL certified)</p>
	 <p>1: +Ve 2: -Ve</p>

17.3.7 LED Operation

The LED lights on the front panel will show diagnostic information for the module's operation.

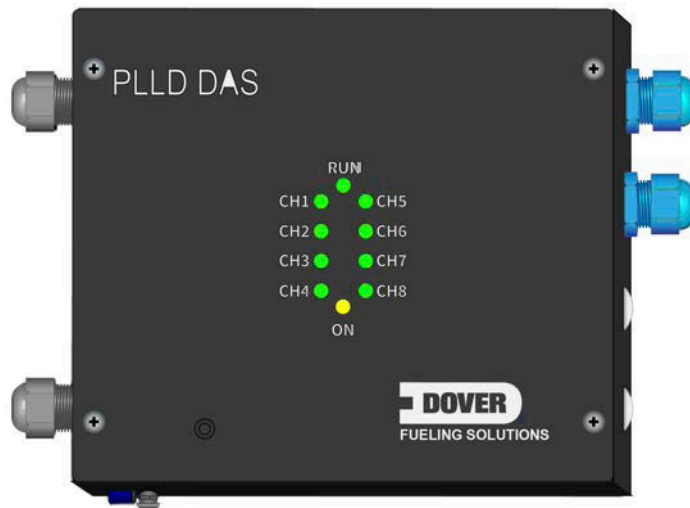

- LED "RUN" (green):
 - When the board is ON but does not communicate correctly with the console (e.g. : a cable is disconnected, a wire is reversed, there is no message from console etc), this LED will flash fast.
 - When the board is ON and communicates correctly with the console, this LED will flash at a "regular" speed.
- LED CH1 – CH8 (green):
 - When the PLLD sensor reading is in range, these LEDs remain ON.
 - When the PLLD sensor is disconnected, these LEDs will remain OFF.
 - When the PLLD sensor reading is in "over-range," these LEDs will flash "very fast."
 - When the PLLD sensor reading is in "under-range," these LEDs will flash "fast."

LED ON (yellow):

When the board has power, this LED will remain ON.

17.3.8 ID Addresses/DIP Switches

A bank of DIP Switches can be found on the main board (see the illustration below). These DIP Switches are used to set an address to the module (see the table below).

Module Address	DIP 1	DIP 2	Information
1	OFF	OFF	Default, setting of 1st DAS module in the RS485 loop
2	ON	OFF	Setting of 2nd DAS module in the RS485 loop
3	OFF	ON	Setting of 3rd DAS module in the RS485 loop
4	ON	ON	Setting of 4th DAS module in the RS485 loop

If two or more DAS modules are connected in the RS485 loop, make sure that the DIP Switch settings are adjusted correctly.



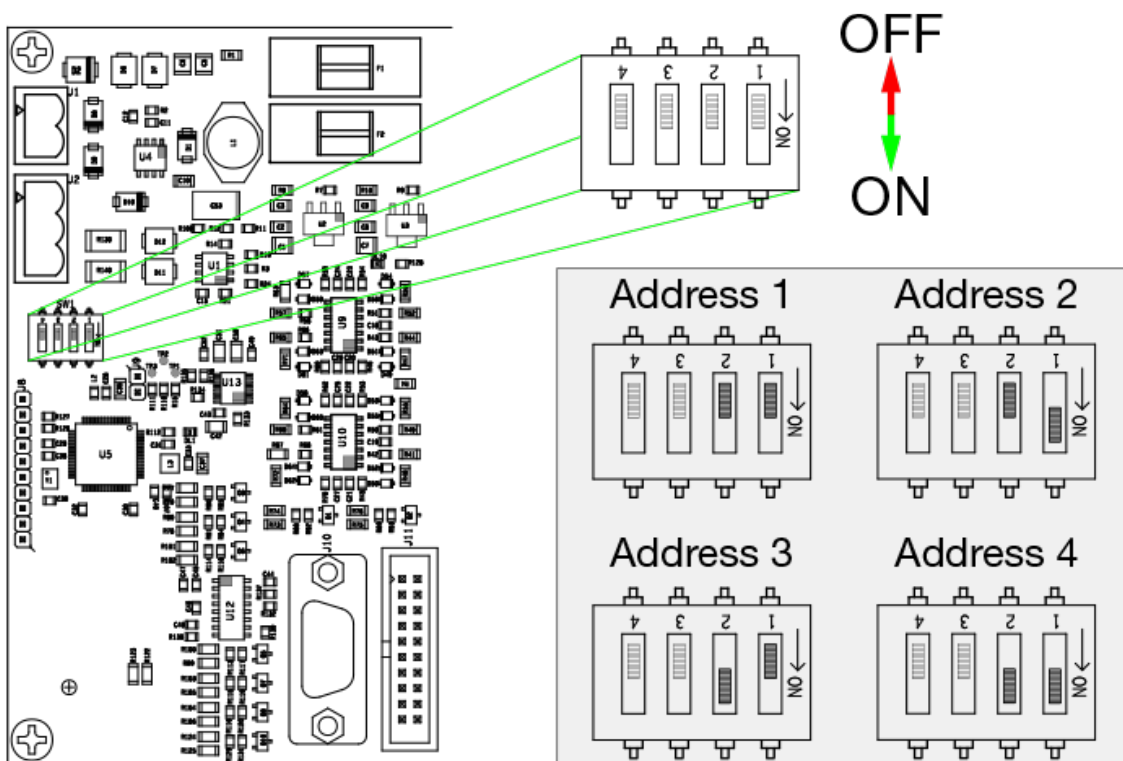

NOTE: DIP Switches 3 and 4 are not used and should remain in the OFF position.



17.4 Maintenance

Refer to and obey the maintenance procedures as specified in **EN 60079-17** for maintenance and inspection in explosive atmospheres.

 WARNING!	
	It can be dangerous to open this module! Maintenance must only be done by approved personnel or the manufacturer of this unit. Maintenance of electrical connections must only be done by approved and certified personnel (refer to this installation manual). Do not open the internal part of this device. The level of safety of the equipment can be compromised if access is made to the main board.

 NOTICE!	
	Changes to this console are not permitted unless they are approved by the manufacturer.



IMPORTANT: *Do regular inspections to make sure the console is clean and that the condition of the console and its connections operate satisfactorily.*

Do not use compressed air or liquid detergents to clean the touchscreen or the console. Clean the touchscreen and the outside of the console with a monitor/TV cleaning cloth.

17.5 Safety Instructions - Control Drawing

Safety instructions (for ATEX installations) or Control Drawing (for UL installations) are annexed to the hard copy version of this document.

18 OM4 Output Module (Optional)



Figure 18-1 OM4 Output Module



The OM4 Output Module has four (4) relay positions. Four (4) OM4 units can be connected together for a total of 16 relays. The wiring instruction on the inside of the OM4 shows the correct Petro-Net communications and power connections.

See the tank-gauge console Configuration Manual for information on alarms, events and Output Module relay configuration.

Some typical OM4 functions include:

- Stop a submersible pump if a low product level is sensed in a tank.
- Cause an alarm when high product is sensed in a tank.

18.1 Safety Precautions



 WARNING!	
	<p>DO NOT connect the OM4 output Module directly to a submersible pump! The OM4 controls pumps INDIRECTLY, through relays or contactors.</p>
	<p>There can be high voltages in the OM4. Servicing of the unit must only be done by an approved technician.</p>
	<p>The output relays in the OM4 are not intrinsically safe! Before you do servicing of the OM4 unit, disconnect the power. Power to and from the relays must also be disconnected.</p>
	<p>Do not put probe or sensor wiring in conduit that contains wiring for devices that are connected to the OM4 Output Module.</p>

18.2 Codes

Relay wiring is in the Class 1 wiring category. Refer to the National Electrical Code (NFPA No. 70) and the Motor Fuel Dispensing Facilities and Repair Garages Code (NFPA No. 30A) to make sure your installation is correct. The installer must know and obey all applicable local codes in the country or county where this unit is installed.

18.3 Hazardous Area Definition

A fuel dispenser is a hazardous area as specified in the National Electrical Code.

 DANGER!	
	<p>Do not install the OM4 Output Module in a hazardous area.</p>
	<p>Do not connect this unit to devices that are in a hazardous area.</p>

18.4 OM4 Technical Specifications

OM4 Technical Specifications	
Field Wiring Rating:	105°C, 600V Type RH. TW, RFH-2 or equivalent
Power Requirements:	12 VAC, 0.5A Max.
Dimensions (W x H x D):	15 cm x 15 cm x 10 cm (6" x 6" x 4")
Temperature Rating:	0°C – 40°C (32°F – 104°F)
Relay Output Rating:	5A @ 240 VAC; 5A @ 24 VDC

18.5 Product Certifications

- Electronic Testing Labs Canada (cETL)
- Electronic Testing Labs (ETL)

18.6 OM4 Installation

The OM4 must be installed on a wall. Use only the drilled installation holes supplied on the unit. Knockout locations are shown below. OM4 Modules must have communication connection to the console and AC power.

The OM4 module is not NEMA-rated. Do not install this unit outdoors where bad weather conditions can occur.

Use only the supplied knockouts. Seal all unused knockouts.

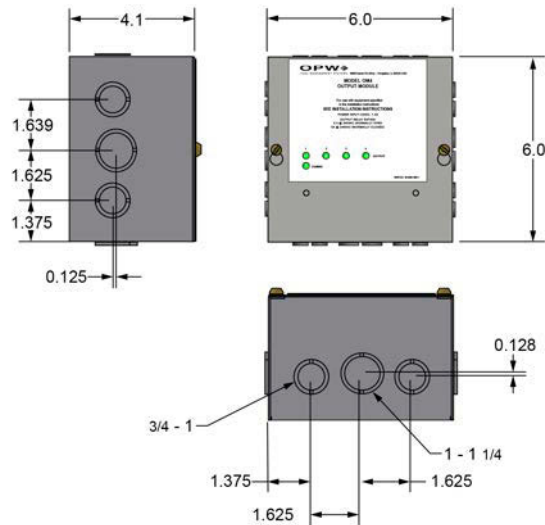

Figure 18-2 OM4 Dimensions and Knockout Locations

18.7 OM4 Connections

See the wiring instructions inside the unit (see the 54-0371 label illustration below) for the correct PetroNet communications and power wiring instruction.



NOTE: The Petro-Net twisted pair cable (OPW-FMS p/n 12-1029) can connect to the console and to other devices that support the Petro-Net over RS485 protocol. Maximum length for all parallel connected devices is 5,000 feet (1524 meters). Petro-Net polarity must be kept for the console and all devices through the entire system.

Connect all relay wiring to the correct terminal block(s).

Figure 18-3 OM4 Wiring Connections and Wiring Instruction Label 54-0443

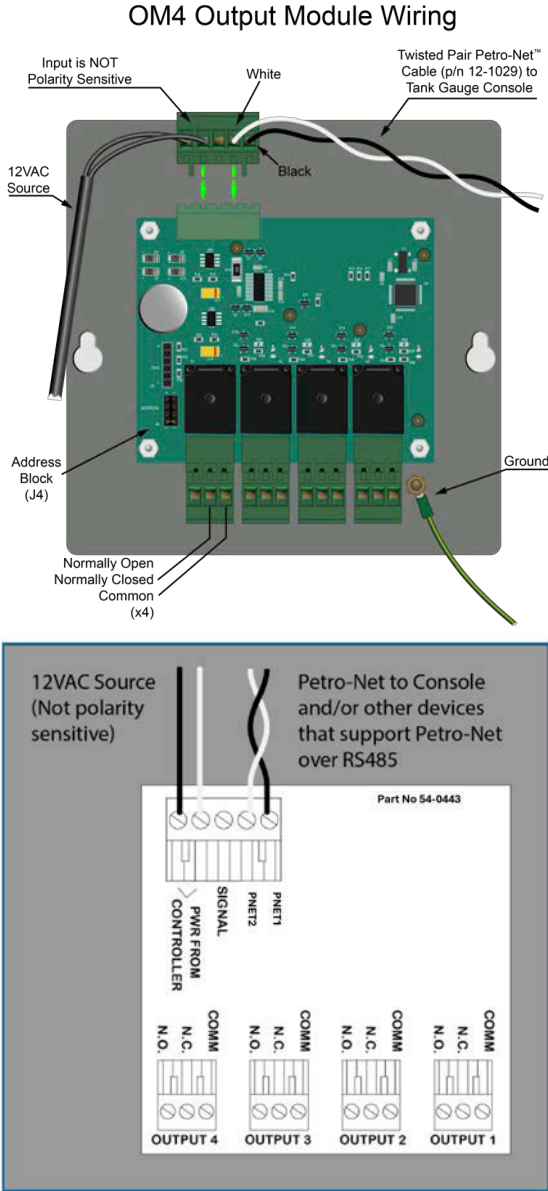

18.8 Petro-Net Address Jumper Settings

 **WARNING!**

 Do not change the module jumpers while the module is energized. The relay positions must not be energized during jumper adjustment.

When more than one OM4 Module is installed in a system the Petro-Net address must be set in the jumper block for each module. Each of the modules must be given a different address so they can be correctly identified in the Petro-Net protocol. The Address block (J4) is located in the bottom left corner of the OM4 board next to the Output 4 connector.

To install two (2) or more OM4 Output Module units:

- Remove the nuts that attach the aluminum cover.
- Remove the cover to get access to the circuit board.
- Set the jumpers to the correct address.
- Put the aluminum cover back on the unit.
- Attach and tighten the nuts.

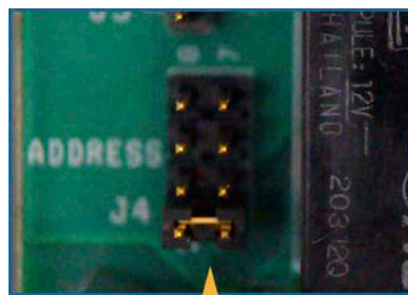

Set the jumpers to the number of OM4 Modules to be installed. The Address block is located in the bottom left corner of the OM4 board

The photo shows the jumpers set for Address #1.

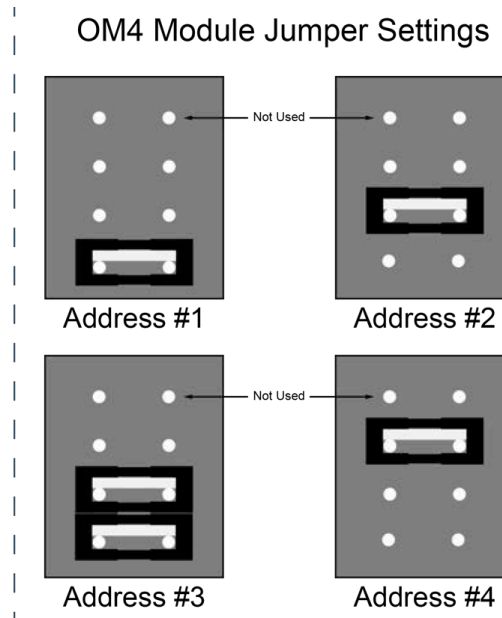

Figure 18-4 OM4 Jumper Settings for Multiple OM4 Operation

19 Tank Alert (Overfill Alarm) (Optional)



The MagLink LX Plus or LX Ultimate console can use one of its internal output contacts or an output relay of a connected OM4 Module to cause an overfill alarm condition in a connected Tank Alert. The Tank Alert has a buzzer and an external light to tell you of an overfill condition or high-product alarm.



NOTE: *The overfill alarm can be set to operate with any alarm that has relay 1 or relay 2 operation.*

19.1 Safety Information

WARNING!	
	EXPLOSION or FIRE HAZARD. Do not install this unit in a hazardous location as specified by the National Electrical Code, ANSI/NFPA 70.
	ELECTRICAL SHOCK HAZARD. Disconnect power before you install or when servicing this unit. Only an approved technician can install or do the servicing of this unit. Refer to applicable electrical and plumbing codes.

19.2 Tank Alert Specifications

Tank Alert Specifications – 120V	
Voltage:	120 VAC, 50/60 Hz
Enclosure Dimensions (H x W x D):	6.5 x 4.5 x 3 inches (16.51 x 11.43 x 7.62 cm)
Alarm Horn:	Alarm Horn: 85 decibels at 10 feet (3 meters)
Alarm Beacon:	UL Listed, Type 4X beacon assembly
Auxiliary Alarm Contacts (Optional):	120 VAC. 5 amps max., 50/60 Hz
Pre-Mounted Terminal Block (Optional):	20 amps, 120/230 VAC

Tank Alert Specifications – 240V	
Voltage:	220-240 VAC, 50/60 Hz
Enclosure Dimensions (H x W x D):	6.5 x 4.5 x 3 inches (16.51 x 11.43 x 7.62 cm)
Alarm Horn:	85 decibels at 10 feet (3 meters)
Alarm Beacon:	UL Listed, Type 4X beacon assembly
Auxiliary Alarm Contacts (Optional):	240 VAC. 5 amps, 50/60 Hz
Pre-Mounted Terminal Block (Optional):	240 VAC, 20 amps

19.3 Tank Alert Installation

The Tank Alert can be installed in a building or an outdoor location.

Two (2) #8 x 1.25 self-tapping screws and sealing washers are included with the Tank Alert. Select an installation location over a wall stud or use wall anchors. The illustration below shows the installation screw hole locations.

Drill holes of the correct size for an applicable conduit.



IMPORTANT: Be careful to not cause damage to internal components when you drill holes for conduit.

Attach the conduit to the Tank Alert enclosure. Apply a sealant around the conduit(s) to keep gases or fluids out of the enclosure.

19.4 Tank Alert Wiring



NOTE: Refer to the [LX Plus Field Wiring Diagram](#) (p. 161) for wiring connections inside the Tank Alert enclosure.



IMPORTANT: Use a minimum gauge 14 AWG stranded copper wire.

See the connection diagram below for relay (internal or OM4) and power connections to the Tank Alert.

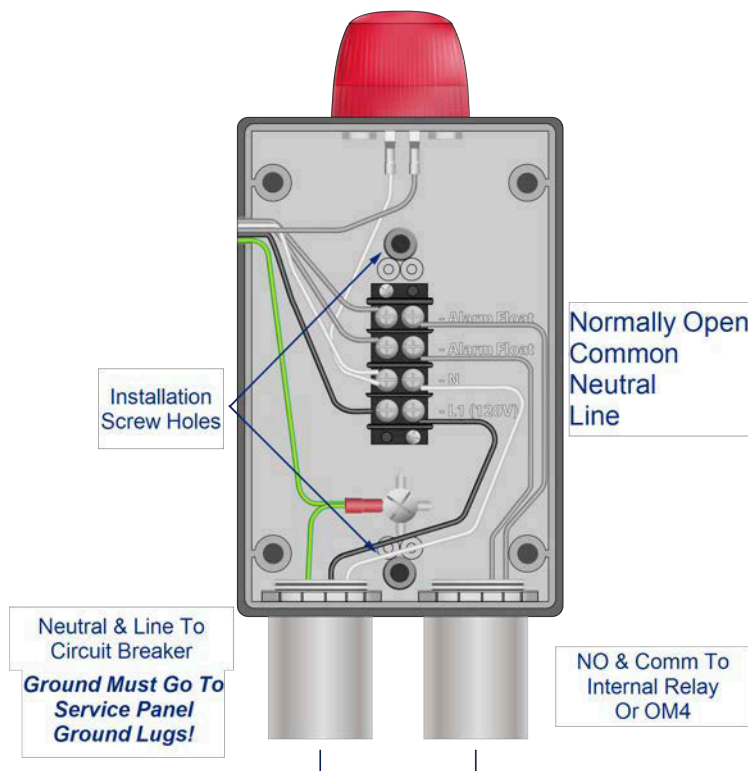

20 M00-20-8319 VSmart Module (Optional)



Figure 20-1 VSmart Module (OPW-FMS Part Number 20-8319)

The VSmart Module is used to connect monitored devices (e.g., probes, sensors, leak detection devices) to the tank-gauge system through Intrinsically Safe (I.S.) barriers. The VSmart Module can contain one (1) or two (2) 4-channel I.S. barriers.

There are two (2) types of I.S. barriers that can be used with a VSmart Module, a 12 -volt model (for 924/924B Probes, DMP 1-Wire probes and Smart Sensors) and a 24-volt model (for Model 7100V AST Flex Probes and EECO Probes).



NOTE: Conduit is recommended for Petro-Net connections between VSmart Modules and consoles, but it is not required.



IMPORTANT: Refer to the Console Wiring section of the M2020 Integra Installation Guide for important information on Petro-Net wiring, wireless connections and Ethernet connections between the VSmart module, Integra 500 console and applicable peripheral devices.

20.1 VSmart Specifications

VSmart Specifications	
Dimensions:	Width: 28.7 cm (11.3 in) Height: 14.2 cm (5.6 in) Depth: 14.7 cm (5.8 in)
Standard Voltage Supply:	105 to 265 VAC, 50-60 Hz
Power Consumption:	60 watts maximum
Temperature Range:	-40°C to 70°C (-40°F to 158°F)
Device Capacity:	Up to two (2) I.S. Barriers Up to eight (8) Barrier Positions
Maximum Total-Run I.S. Wiring Length ¹ :	304.8 m (1,000 ft) Use Belden 88770
Petro-Net™ Communication Wiring Requirement:	18-AWG/ 0.75 mm ² twisted pair, oil-and-gas resistant (TFFN, THHN, THWN)
Maximum Petro-Net™ Extension using RS485:	1524 m (5,000 ft) ²
Barrier Part Numbers:	P/N: 20-4344 12V Barrier P/N: 20-4345 24V Barrier

1. Maximum I.S. Wiring Length is the maximum length of cable that can be used to connect all probes or sensors on one channel. The length includes the run of cable from an I.S. Barrier to each probe or sensor board in the string.
2. Maximum Petro-Net extension using RS-485 is the maximum length of Petro-Net cable that can be used to connect all Petro-Net devices.

20.2 VSmart Module Installation

The VSmart module must be installed on a wall. Use the supplied tabs. Module installation tab and conduit knockout dimensions and locations are shown in the drawings below.

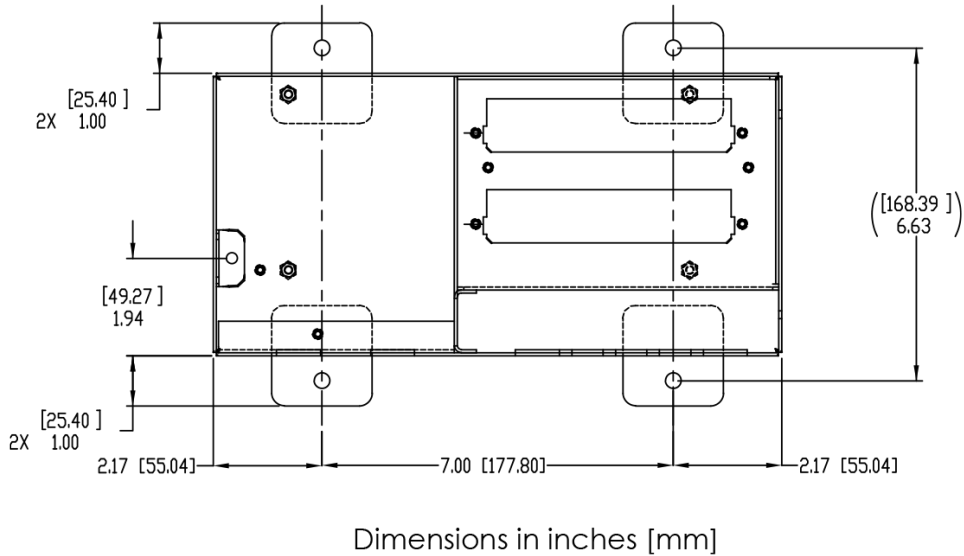

Figure 20-2 Installation Tab Locations and Dimensions

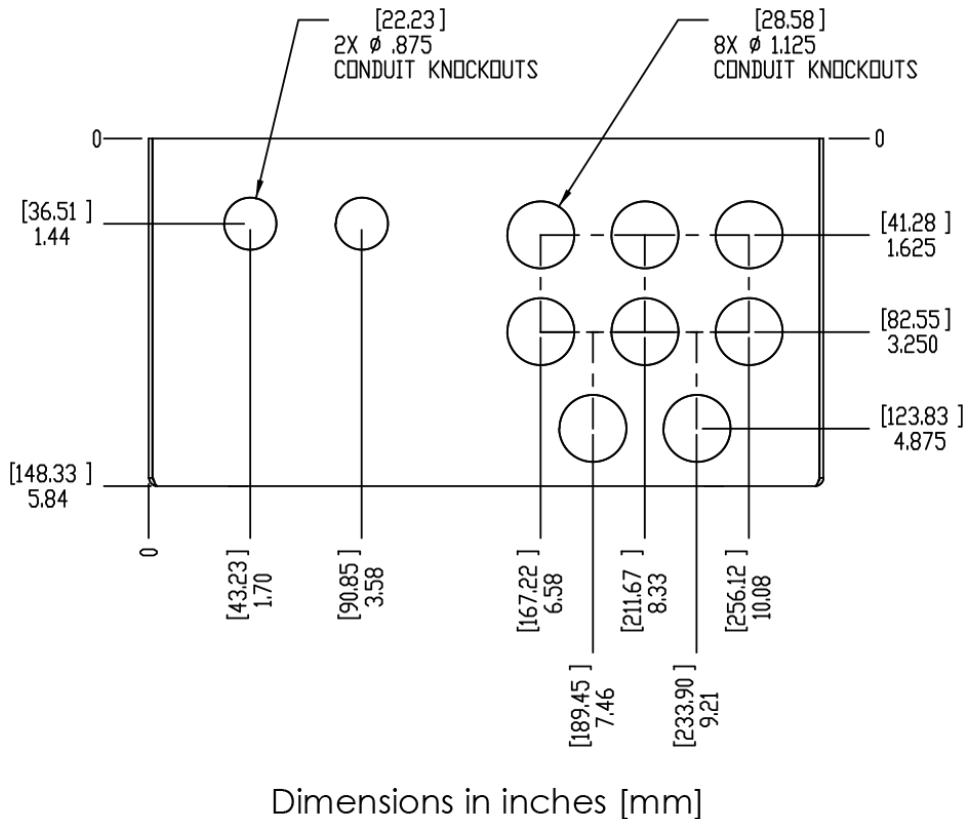

Figure 20-3 Conduit Knockout Locations and Dimensions

20.2.1 Probe & Sensor Conduits



IMPORTANT: You must obey all local, state and federal regulations when this product is installed. Rigid steel conduit could be required. It is recommended to use rigid steel conduit when possible.

Each VSmart Module is equipped with eight (8) ¾-inch (19 mm) knockouts to accommodate conduit for probe cables and sensor wiring. Two (2) additional ½-inch (13 mm) knockouts are provided for power and communication wiring conduits.

For probe and sensor field connections, always use a weatherproof junction box.

20.2.2 Circuit Breaker Conduits

Install ½-inch (13 mm) conduit from the power knockout in the console to the circuit breaker box. Install a ½-inch (13 mm) conduit from the power knockout in each VSmart Module to the circuit-breaker box.

20.3 External VSmart Module Wiring



IMPORTANT: VSmart modules must have dedicated AC power and two (2) ground connections for the module and barrier.

- Pull two (2) AC power wires and one (1) ground wire (14-AWG minimum) from the circuit breaker to each module. More than one module can use the same circuit as long as they are not more than the circuit breaker rating.
- Pull one (1) ground (12-AWG minimum) from the circuit breaker for the I.S. barrier ground.



NOTE: See the Integra 500 Field Wiring Diagram for more VSmart Module wiring information.

- All OPW equipment must be on the same phase of AC power.

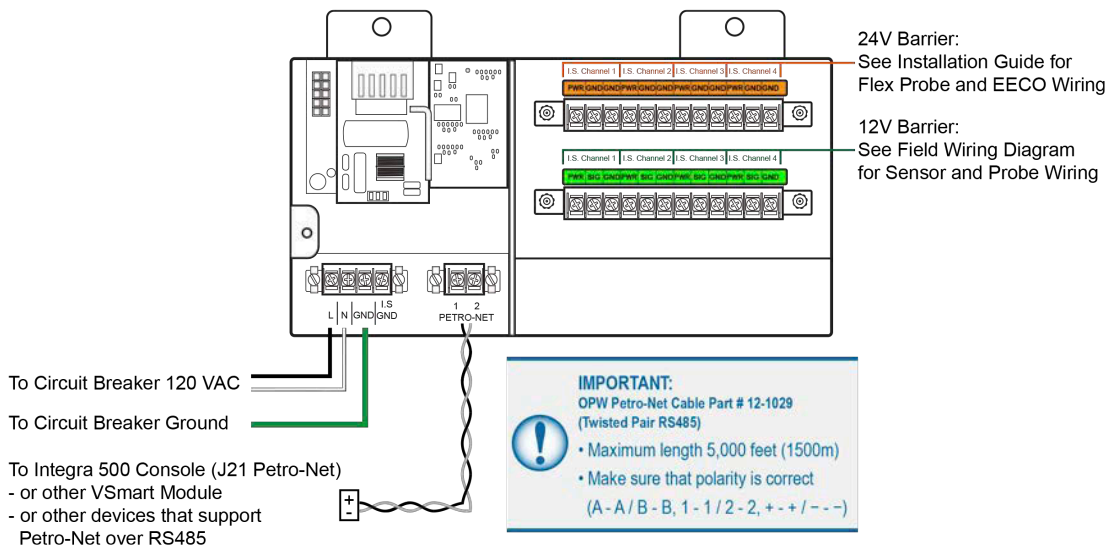

Figure 20-4 External VSmart Wiring

20.3.1 Device Wiring to Barriers

Device Wiring to Belden 88770



NOTE: Belden 88770 is the recommended cable. However, Belden 88760 (or equivalent) is a satisfactory alternative for most environments/installations.

The illustrations below show how 924B probes, DMP probes and Smart Sensors should be connected to Belden 88770 field wiring in junction boxes and how the field wiring is connected to a VSmart 12V Barrier.

924B Probe Wiring to Belden 88770 Field Wiring

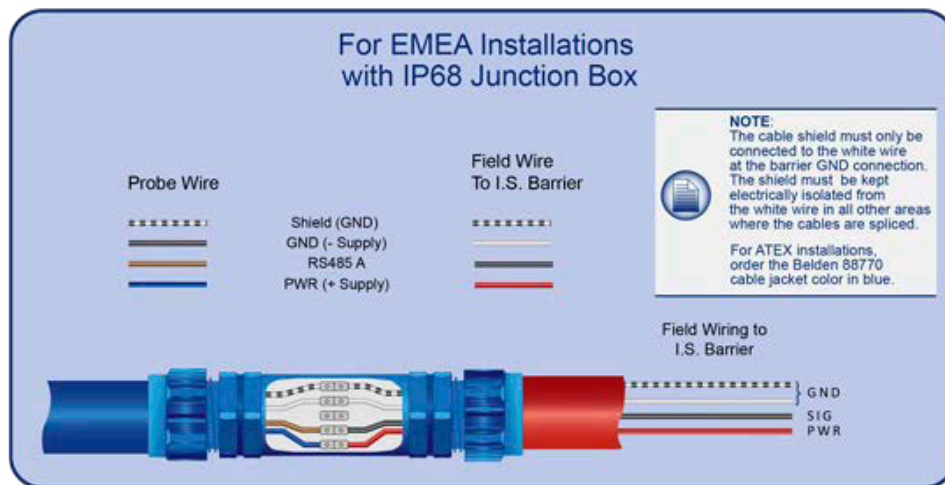
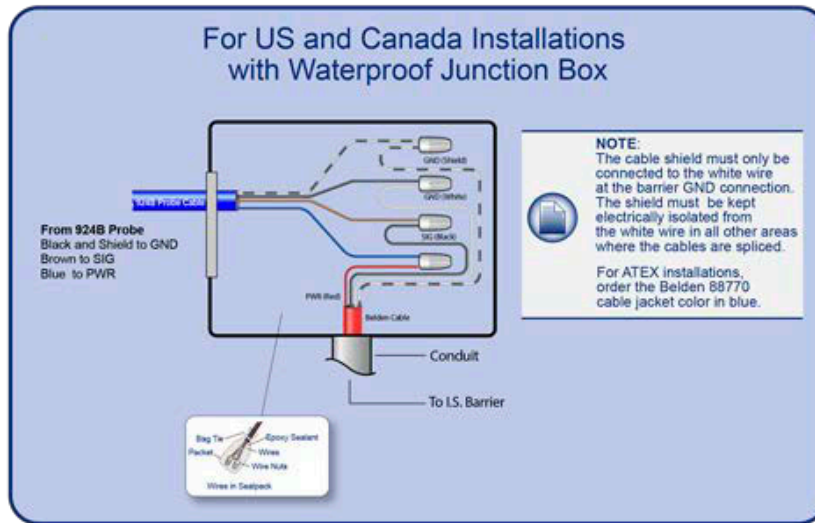

DMP Wiring to Belden 88770 Field Wiring

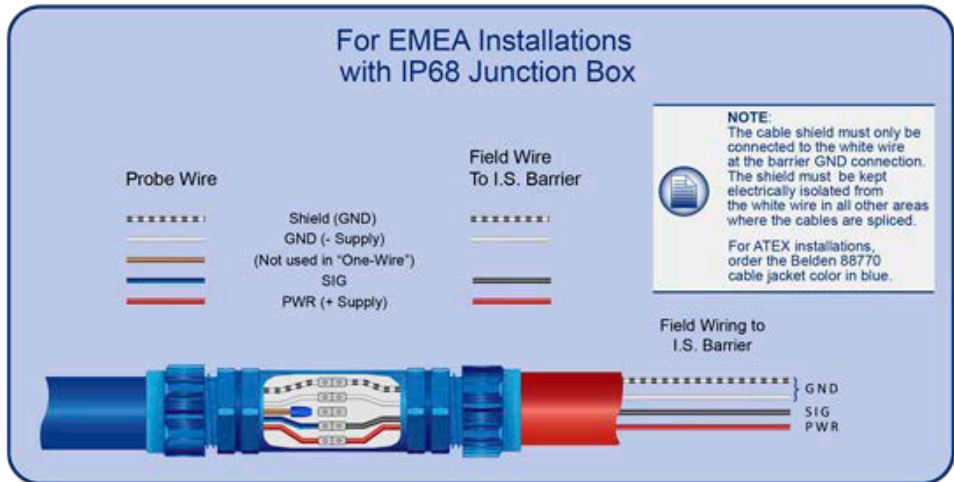
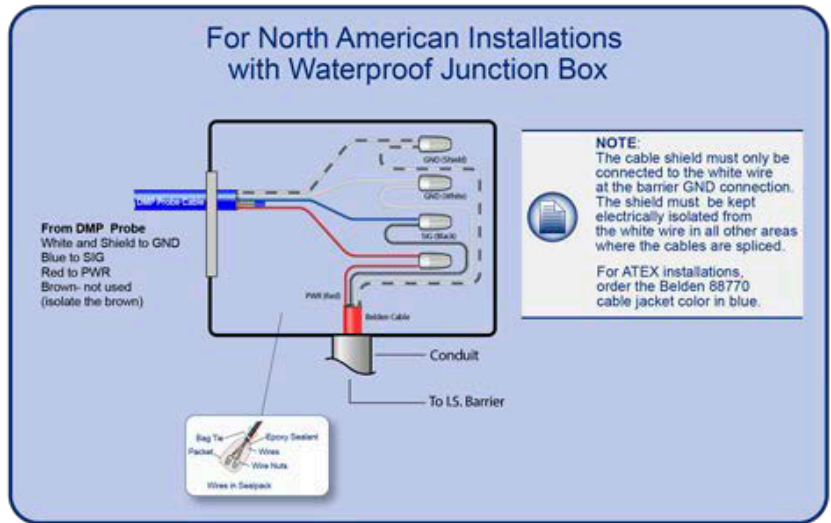

Smart Sensor Wiring to Belden 88770 Field Wiring

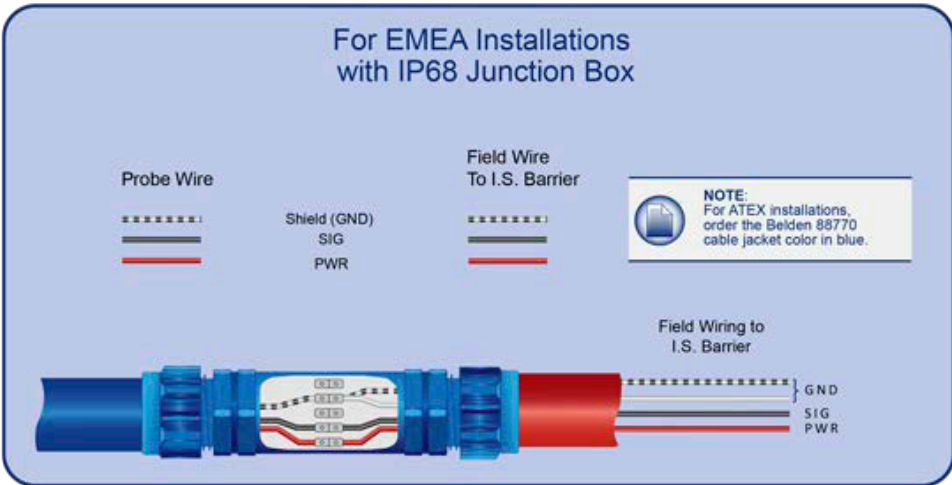
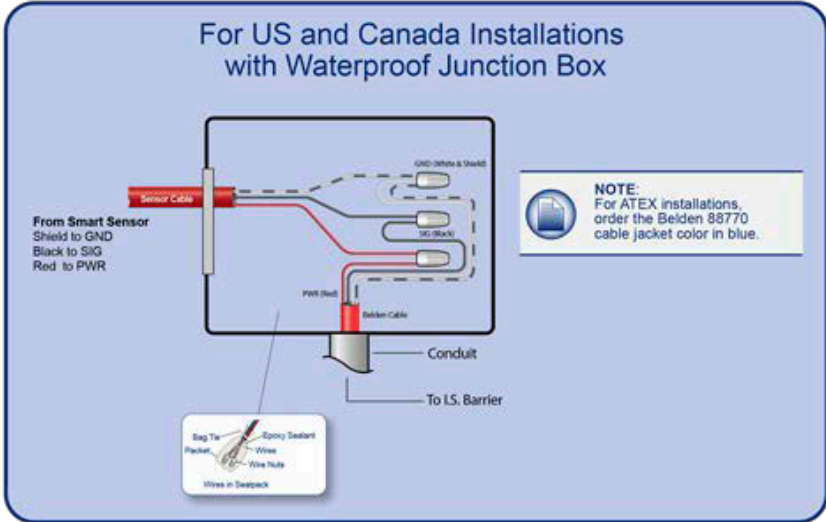

12V Barrier Channel Wiring

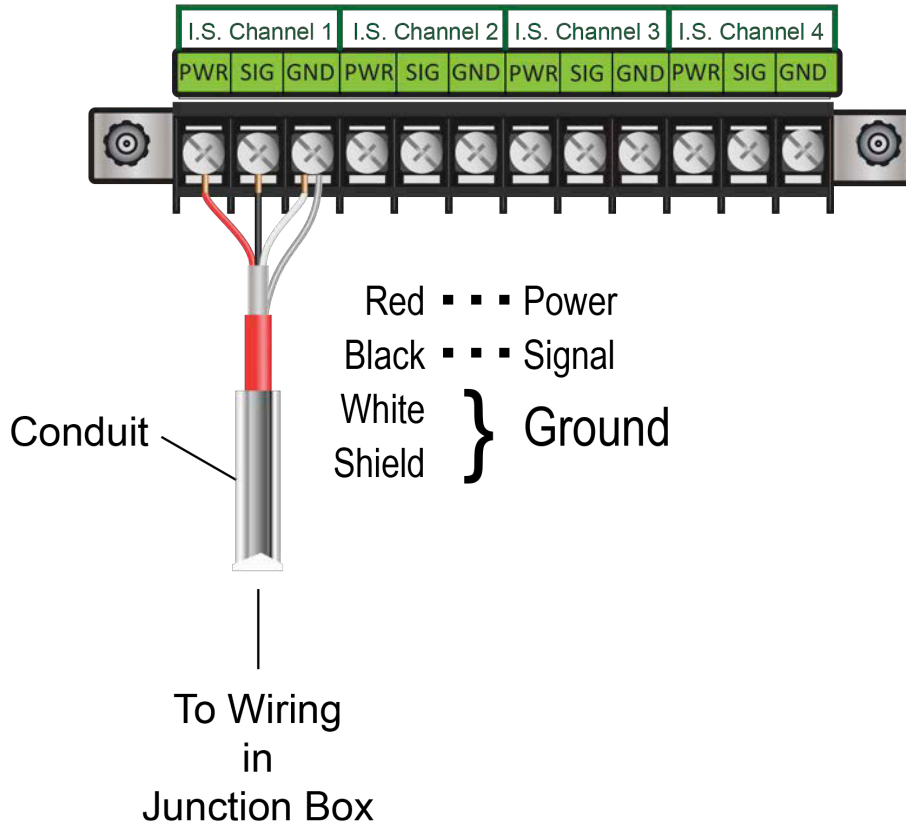

NOTE: Probes and sensors should not be mixed on the same I.S. channel of the barrier within the VSmart module as they will not be detected properly!



Probes and sensors can be mixed on the same I.S. channel only within the built-in ISB of the MagLink LX Plus and LX Ultimate consoles

Device Wiring to Belden 88760 (or equivalent)



NOTE: This is for wiring installations that have Belden 88760 (or equivalent) cable installed before the installation of new probes. New installations should use Belden 88770 if possible (see the section above).

DMP wiring to Belden 88760 (or equivalent) Field Wiring

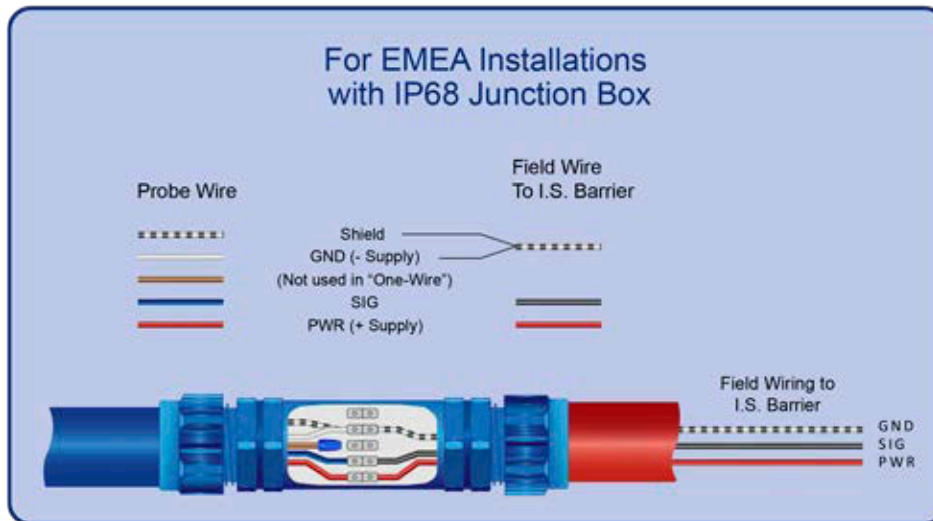
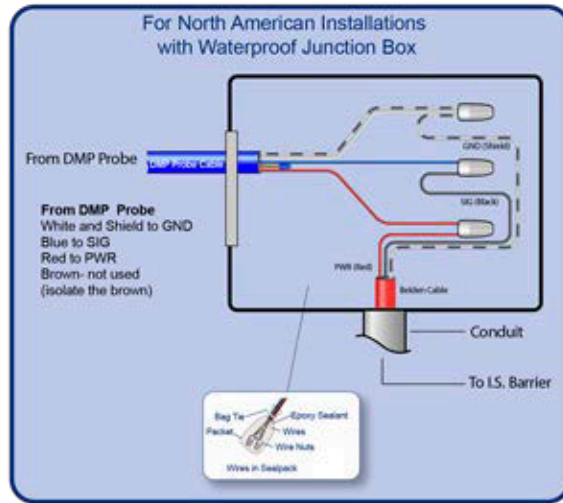

924B Probe Wiring to Belden 88760 Field Wiring

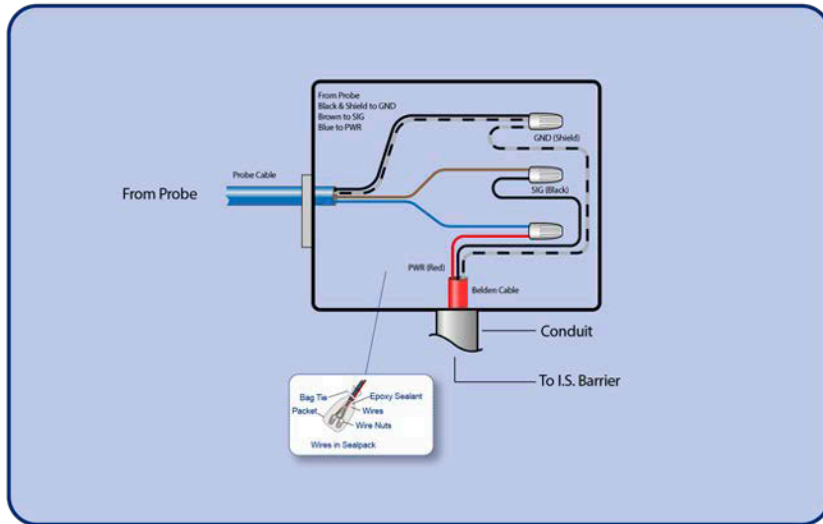

For EMEA Installations with IP68 Junction Box

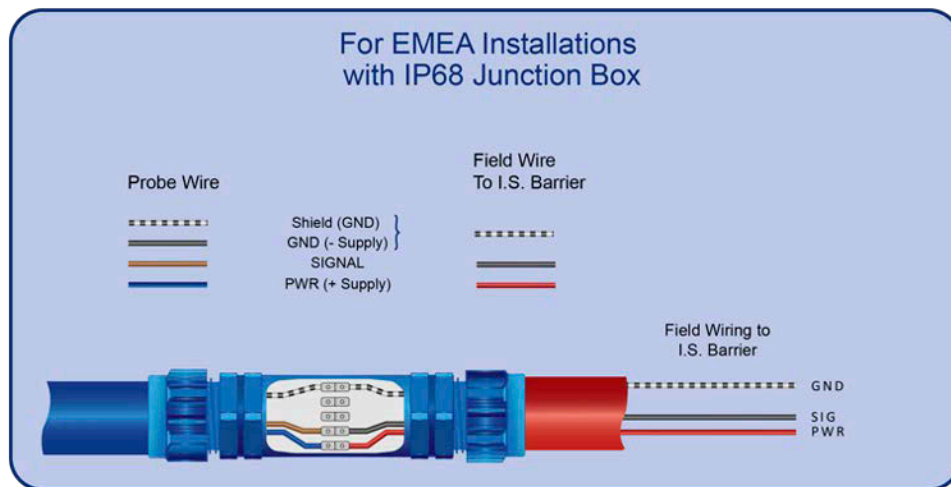

Smart Sensor Wiring to Belden 88760 Field Wiring

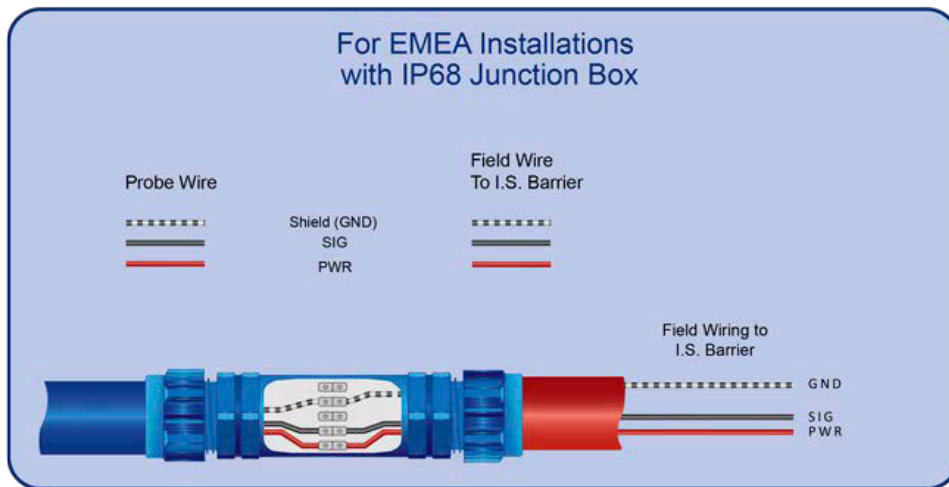
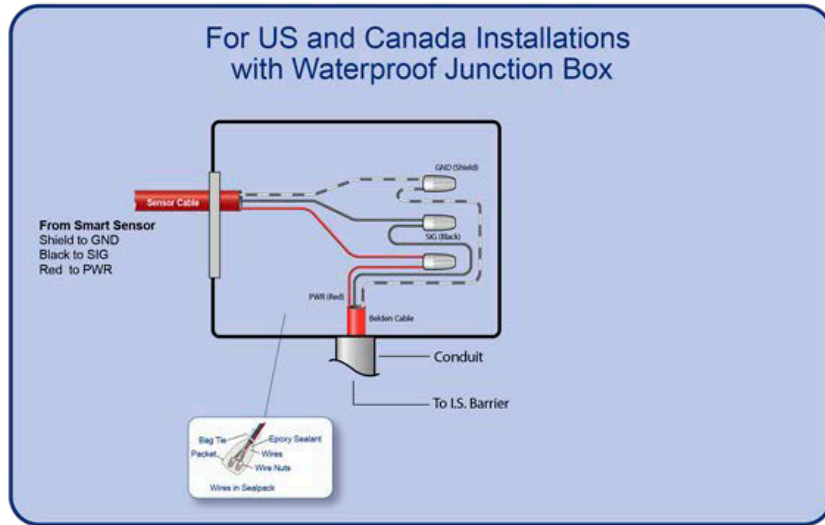

20.3.2 Petro-Net Address

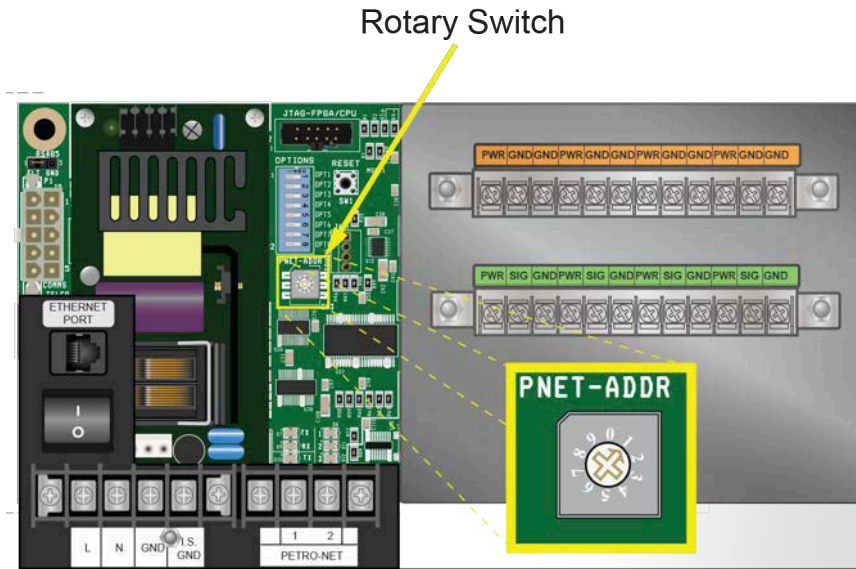

VSmart modules must be given an identification number to correctly communicate with the system through the Petro-Net protocol. This number must be different than all other VSmart modules in the system.

A small rotary switch is located on the PC board under the DIP-Switch block. The switch has 10 positions, from “0” to “9.” A small arrow on the switch points to the applicable position. The default setting is “1.”



NOTE: Although the switch has 10 settings, only settings 1-8 can be used. DO NOT set the switch to “0” or “9.” The module will NOT be sensed by the system.

To set the Petro-Net address:

1. Turn the module power OFF.
2. Use a ¼-inch (6 mm) blade screwdriver to carefully turn the rotary switch to the applicable location.
3. Turn the module power to ON.

Do not change the module number while the module power is ON.



NOTE: The eight-position DIP-Switch must stay in the closed position for normal operation.

20.4 VSmart Capacities

Refer to the table that follows for capacities of the VSmart Module in connection with different peripheral devices.

I.S. Barrier Capacity (up to two [2] I.S. Barriers per Module, four [4] positions per Barrier)		
	Maximum each Channel	Maximum each I.S. Barrier
Sensors:	12	64
924B and DMP 1-Wire Probes:	3	12

Where there can be more than one device on a barrier channel, devices can be connected in parallel. This is referred to as a "multi-drop" connection. Each type of sensor or probe that is connected to a module is sensed through IntelliSense™ Technology.

For more information on the VSmart's Multi-Drop functions, use the QR Code below to see the video "[Multidrop Probe & Sensor Wiring Instructions](#)."



21 Close and Startup

The steps below show the last steps of the installation procedure.

- Connect the ribbon cable that connects the back panel with the front panel.
- Align the Front Panel of the console with the Rear Panel that was attached to the wall.
- Install the three (3) cover screws.
- Connect the power cable.
- Energize the main electrical panel.
- Put the power switch of the console in the ON ("I") position. The console will now start up.

22 Connections to Management Systems (POS-FCC)

The LX Plus console can be connected through the RS232 COM ports or through the TCP/IP port to management systems. These connections use a range of tank gauging protocols such as OPW PV4 and VR TLS350.

The RS232 schematics for different forecourt controllers (FCC) are shown below.

22.1 TOKHEIM FUEL POS / DIALOG

The illustration and table below show the connection for the FUELS POS / DIALOG Fuel management systems:

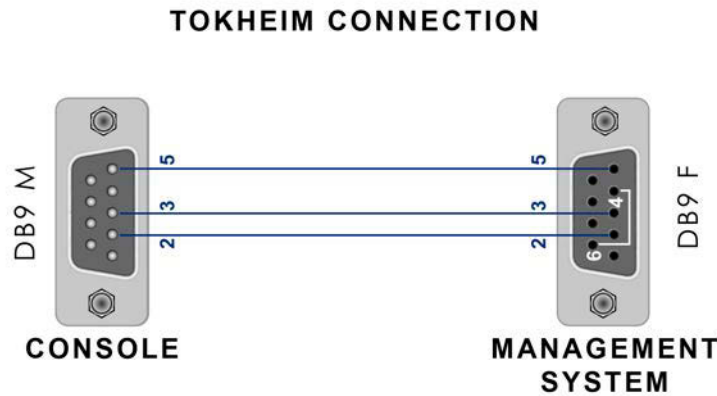

Console (DB9)	DIALOG System (DB9)
PIN 2	PIN 2
PIN 3	PIN 3
PIN 5	PIN 5
---	Connect PIN 4 with PIN 6

22.2 Wayne Fusion

The illustration and table below show the connection for the Wayne Fusion management system:

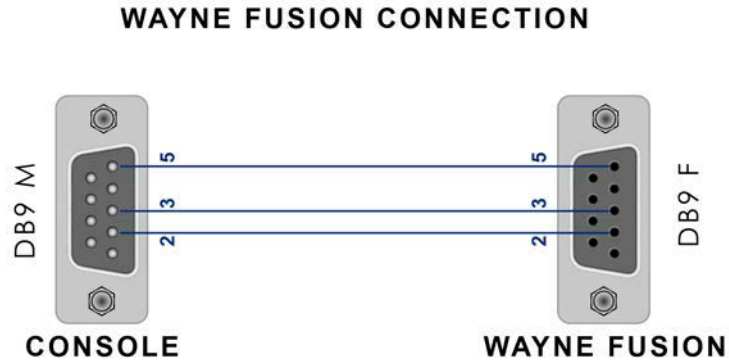

Console (DB9)	DRESSER (PIGNONE) System (DB9)
PIN 2	PIN 2
PIN 3	PIN 3
PIN 5	PIN 5





IMPORTANT: It is recommended to not have more than 15 meters for serial connections between the console and the management system through RS232.

23 Maintenance and Technical Support

23.1 Maintenance

Refer to and obey the maintenance procedures as specified in **EN 60079-17** for maintenance and inspection in explosive atmospheres.

 WARNING!	
	It can be dangerous to open this console! Maintenance must only be done by approved personnel or the manufacturer of this unit.
	Maintenance of electrical connections must only be done by approved and certified personnel (refer to this installation manual).

 NOTICE!	
Changes to this console are not permitted unless they are approved by the manufacturer.	



IMPORTANT: Do regular inspections to make sure the console is clean and that the condition of the console and its connections operate satisfactorily.

Do not use compressed air or liquid detergents to clean the touchscreen or the console. Clean the touchscreen and the outside of the console with a monitor/TV cleaning cloth.

23.2 Technical Support

When you ask for technical support from DFS, it is recommended that you give direct access to the console over the internet through ports 3000 and 22. As an alternative, the console can be connected to a site computer and technical support can get access through a third-party program (such as TeamViewer). If technical support cannot get access to the console in one of these two methods, the user must supply technical support with the log files and the database backup of the console.

Refer to the "Utility" section of the M2051 LX 4/LX Plus Configuration manual for more information on log files and the database backup in the console.

Appendix A NWGLDE Certifications

Dover Fueling Solutions

http://www.nwglde.org/evals/dover_fueling_b.html

Issue Date: October 21, 2022

**Dover Fueling Solutions
MagLink LX
(Dover Fueling Solutions 924B probe with 2 inch dia Floats)**

AUTOMATIC TANK GAUGING METHOD

Certification	Leak rate of 0.2 gph with PD = 99.70% and PFA = 0.30% Leak rate of 0.1 gph with PD = 95.56% and PFA = 4.41%.
Leak Threshold	0.1 gph for leak rate of 0.2 gph. 0.05 gph for leak rate of 0.1 gph. A tank system should not be declared tight if the test result indicates a loss or gain that equals or exceeds this threshold.
Applicability	Gasoline, diesel, aviation fuel, fuel oil #4, solvents, waste oil, other bio-diesel and ethanol blends compatible with probe floats.
Tank Capacity	Maximum of 20,650 gallons. Tank must be minimum 14% full for leak rate of 0.2 gph. Tank must be minimum 15% full for leak rate of 0.1 gph.
Waiting Time	Minimum of 8 hours between delivery and testing for leak rate of 0.2 gph. Minimum of 12 hours between delivery and testing for leak rate of 0.1 gph. There must be no delivery during waiting time.
Test Period	Minimum collection time of 2 hours for leak rate of 0.2 gph. Minimum collection time of 4 hours for leak rate of 0.1 gph. Test data are acquired and recorded by system's computer. There must be no dispensing or delivery during test.
Temperature	Average for product is determined by a probe containing 5 thermistors.
Water Sensor	Minimum detectable water level that can be detected is 1.016 inch. Minimum detectable change in water level that can be detected is 0.0098 inch.
Calibration	Thermistors and probe must be checked and, if necessary, calibrated in accordance with manufacturer's instructions.
Comments	Not evaluated using manifolded tank systems. Therefore, this certification is only applicable when there is a probe used in each tank and the siphon is broken during testing. Evaluated with 2" diameter OPW fuel floats and 2" diameter DMP water floats. Tests only portion of tank containing product. As product level is lowered, leak rate in a leaking tank decreases (due to lower head pressure). Consistent testing at low levels could allow a leak to remain undetected. EPA leak detection regulations require testing of the portion of the tank system which routinely contains product.

<p>Dover Fueling Solutions 6900 Santa Fe Dr. Hodgkins, IL 60525-9909 Tel: (708) 485-4200 E-Mail: atg@doverfs.com URL: www.doverfuelingsolutions.com</p>	<p>Evaluator: Ken Wilcox Associates Tel: (816) 443-2494 Date of Evaluation: 09/15/2021; 9/21/2021</p>
---	---



[Home](#) | [Vendors: A - F](#) | [Vendors: G - M](#) | [Vendors: N - S](#) | [Vendors: T - Z](#) | [Method Index](#) | [Glossary](#) |

Appearance on this list is not to be construed as an endorsement by any regulatory agency nor is it any guarantee of the performance of the method or equipment. Equipment should be installed and operated in accordance with all applicable laws and regulations. For full details, please refer to our expanded "DISCLAIMER" page.

Issue Date: October 21, 2022

**Dover Fueling Solutions
MagLink LX
(Dover Fueling Solutions DMP probe with 2 inch dia Floats)
AUTOMATIC TANK GAUGING METHOD**

Certification Leak rate of 0.2 gph with PD = 97.49% and PFA = 2.51%.
Leak rate of 0.1 gph with PD = 97.10% and PFA = 2.90%.

Leak Threshold 0.1 gph for leak rate of 0.2 gph.
0.05 gph for leak rate of 0.1 gph.
A tank system should not be declared tight if the test result indicates a loss or gain that equals or exceeds this threshold.

Applicability Gasoline, diesel, aviation fuel, fuel oil #4, solvents, waste oil, other bio-diesel and ethanol blends compatible with probe floats.

Tank Capacity Maximum of 20,650 gallons.
Tank must be minimum 14% full for leak rate of 0.2 gph.
Tank must be minimum 15% full for leak rate of 0.1 gph.

Waiting Time Minimum of 8 hours between delivery and testing for leak rate of 0.2 gph.
Minimum of 12 hours between delivery and testing for leak rate of 0.1 gph.
There must be no delivery during waiting time.

Test Period Minimum collection time of 2 hours for leak rate of 0.2 gph.
Minimum collection time of 4 hours for leak rate of 0.1 gph.
Test data are acquired and recorded by system's computer.
There must be no dispensing or delivery during test.

Temperature Average for product is determined by a probe containing 5 thermistors.

Water Sensor Minimum detectable water level that can be detected is 0.681 inch.
Minimum detectable change in water level that can be detected is 0.0098 inch.

Calibration Thermistors and probe must be checked and, if necessary, calibrated in accordance with manufacturer's instructions.

Comments Not evaluated using manifolded tank systems. Therefore, this certification is only applicable when there is a probe used in each tank and the siphon is broken during testing.
Evaluated with 2" diameter OPW fuel floats and 2" diameter DMP water floats.
Tests only portion of tank containing product.
As product level is lowered, leak rate in a leaking tank decreases (due to lower head pressure). Consistent testing at low levels could allow a leak to remain undetected.
EPA leak detection regulations require testing of the portion of the tank system which routinely contains product.

Dover Fueling Solutions
6900 Santa Fe Dr.
Hodgkins, IL 60525-9909
Tel: (708) 485-4200
E-Mail: atg@doverfs.com
URL: www.doverfuelingsolutions.com

Evaluator: Ken Wilcox Associates
Tel: (816) 443-2494
Date of Evaluation: 09/15/2021; 9/21/2021



| [Home](#) | [Vendors: A - F](#) | [Vendors: G - M](#) | [Vendors: N - S](#) | [Vendors: T - Z](#) | [Method Index](#) | [Glossary](#) |

Appearance on this list is not to be construed as an endorsement by any regulatory agency nor is it any guarantee of the performance of the method or equipment. Equipment should be installed and operated in accordance with all applicable laws and regulations. For full details, please refer to our expanded "DISCLAIMER" page.

Appendix B Console Dimensions

Console Front

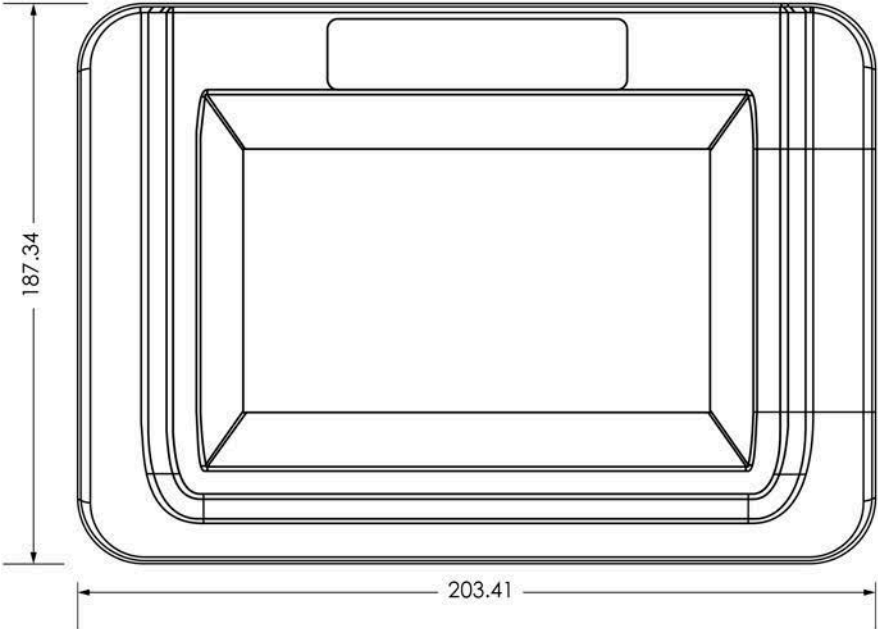

Console Rear

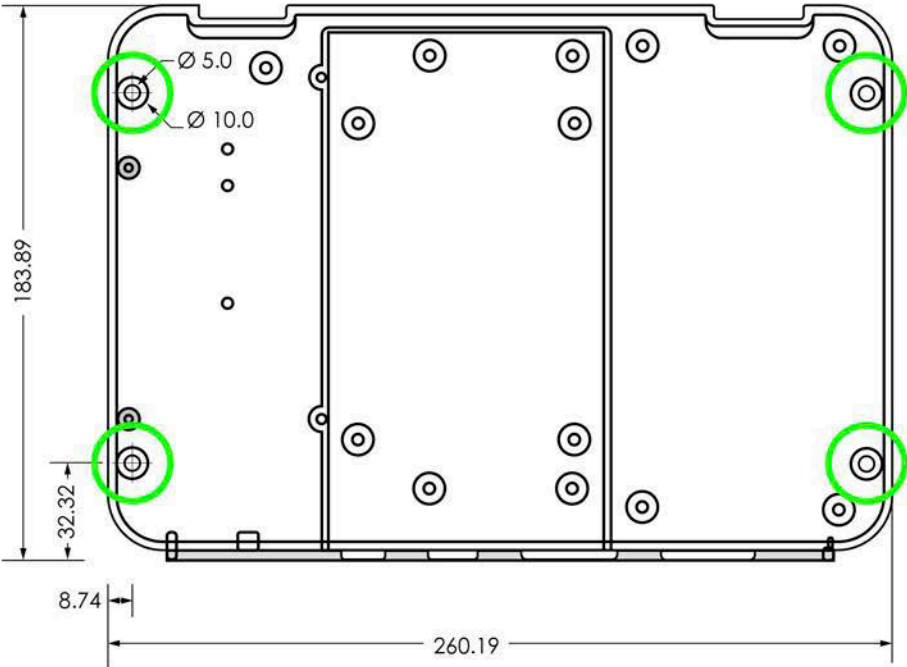

All dimensions expressed in mm

Appendix C Descriptive System Document

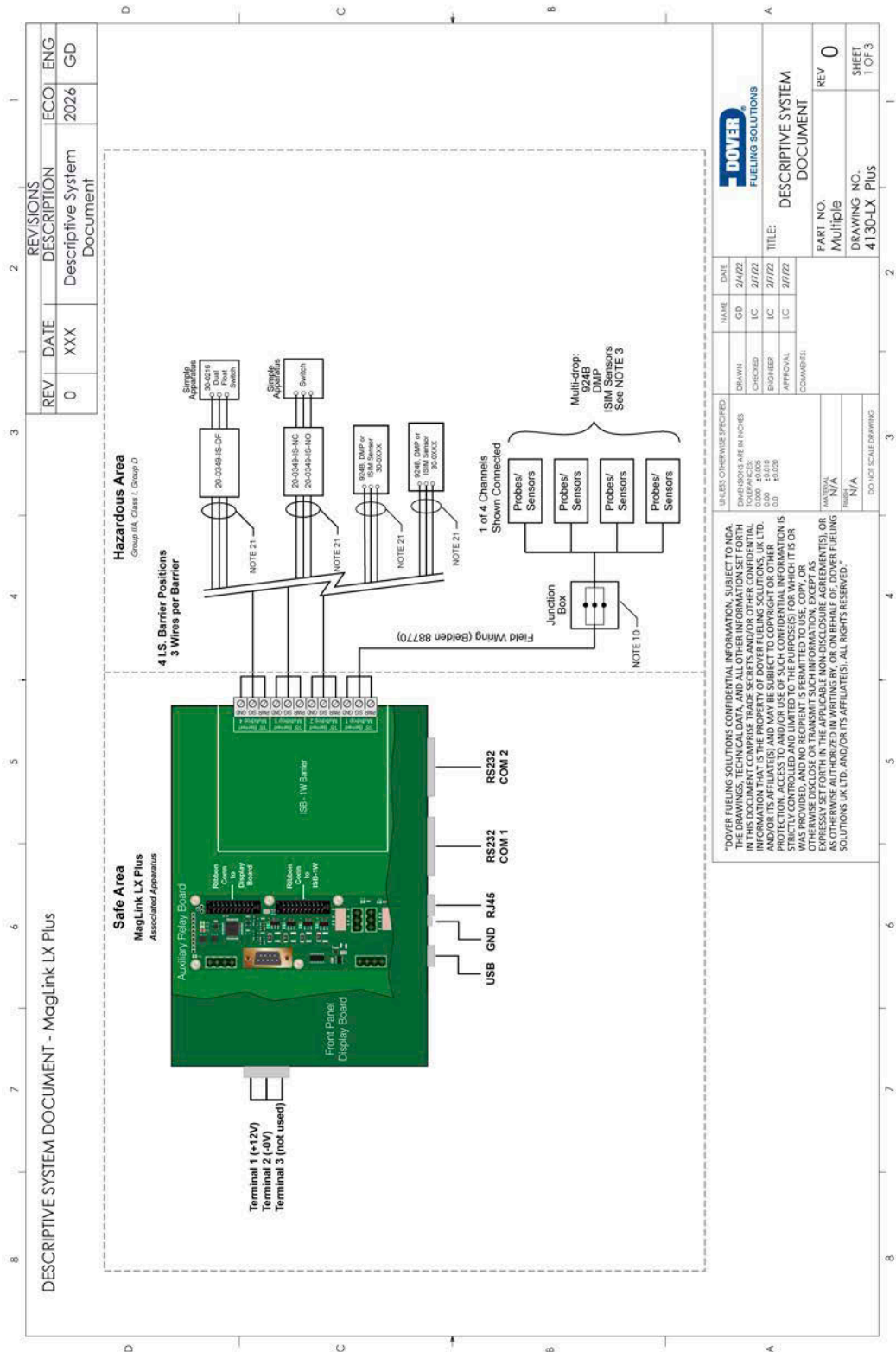

<p>13.) Cable glands must be process-connections considered suitable in accordance with IEC/EN 60079-26. 14.) Special conditions for safe use that are defined in the certificate of conformity and the installation manual must be obeyed. 15.) LX Plus console and all I.S. devices must be installed in accordance with its manufacturer's control drawing and Article 504 of the National Electrical Code (ANSI/NFPA 70) for installation in the United States, or Section 18 of the Canadian Electrical Code for installations in Canada. Other local codes, as applicable. 16.) LX Plus console must not be supplied from or contain, under normal or abnormal conditions, a source of potential with respect to earth in excess of 250V RMS; or 250V DC, um = 250V 17.) LX Plus console output current is limited by a resistor such that the output voltage-current plot is a straight line between open-circuit voltage and short-circuit current. 18.) Associated Apparatus is third party listed as providing intrinsically safe circuits for the application and have Voc or Vi not exceeding Vmax (or Uo not exceeding Ui), Isc or It not exceeding Imax (or Io not exceeding Ii), and the Po of the associated apparatus must be less than or equal to the Pmax or Pi of the intrinsically safe equipment as shown below</p>	<p>DESCRIPTIVE SYSTEM DOCUMENT - MogLink LX Plus</p> <p>NOTES:</p> <ol style="list-style-type: none"> This document shows the intrinsically safe equipment and associated apparatus that together create an intrinsically safe system. The LX Plus console must be installed in an indoor, non-hazardous area in accordance with this document and the installation manual. Only one LX Plus console can be connected to any single intrinsically safe apparatus. Multiple power sources, additional consoles or other associated apparatus, cannot be connected to the same intrinsically safe apparatus. The LX Plus supports a maximum of 12 probes and 24 sensors. It allows mixing probes and sensors on a single I.S. channel by connecting them in parallel. When connecting I.S. devices to the I.S. barrier the console uses a points system to calculate the mix of probes and sensors that can be installed on each of the four (4) barrier positions. Each of the LX Plus console's four (4) barrier positions can have up to a maximum of 12 "points" of connected devices (where probes = 4 points and sensors = 1 point). One barrier position can hold a total of 12 points (3 Tank-Probes, or 12 Smart-Sensors or a mix of probes and sensors). The wiring used to connect I.S. devices to the console must not exceed a capacitance of 328 pF/feet or 100 pF/foot. The total combined cable used to connect I.S. devices to the LX Plus console must not exceed a total cable capacitance of 5.0µF. Recommended cable for field wiring is Belden 88770 or equivalent. Do not exceed an inductance of 0.565µH/feet or 0.2µH/foot for each cable. Do not exceed 200µH/Ohm of a cable's L/R ratio. The total cable length used to connect up to 12 probes and 24 sensors to all LX Plus Barrier positions cannot exceed 2438 meters or 8,000 feet with each position wiring not exceeding 610 meters or 2,000 feet. The barrier ground must be connected directly to the ground bus of the main electrical panel. Use a minimum 4.0 mm² / 10 AWG conductor. Ground connections must be in accordance with IEC/EN 60079-14. The associated apparatus must be connected to a suitable ground electrode per the National Electrical Code (ANSI/NFPA 70), the Canadian Electrical Code, or other local installation codes as applicable. The resistance of the ground path must be less than 1 ohm. Field wiring connections must be made in a weatherproof junction box. Wires and wire nuts must be enclosed in a 3M™ Scotchcast™ Electrical Insulating Resin seal pack assembly (3570G-N). A risk assessment as to the susceptibility of the installation to lightning or other electrical surges must be made. Mitigations must be in accordance with IEC/EN 60079-25. Installers must know the requirements of intrinsically safe devices, comply with all national and local codes and must obey the instructions in the installation manual. The installer must decide if a simple apparatus used with this system complies and conforms to the requirements as follows: <ol style="list-style-type: none"> The simple apparatus must be constructed of passive components only (switches, junction boxes and resistors, etc.) The simple apparatus must be constructed without any sources of stored energy (batteries, capacitors and inductors). The simple apparatus must not be constructed with sources of generated energy that can produce greater than 1.5V and 25mW or have energy sources that can increase the voltage. A simple apparatus with a metallic housing must be able to tolerate a test voltage to earth as defined in IEC/EN 60079-11. Simple apparatus constructions with non-metallic enclosures and enclosures of light metals must comply with IEC/EN 60079-0 sections 7, 8 and IEC/EN 60079-26, clause 4.3.3 Based on the available power within the system, simple apparatus that have electrical components that exceed 20 mm² in total surface area, may be assessed as having a T4 temperature code at the specified ambient temperature range of -40 deg. C to +60 deg. C. other types of simple apparatus must be assessed in accordance with IEC/EN 60079-11, section titled "simple apparatus". A simple apparatus must not contain any means of increasing the available voltage or current, for example DC to DC converters.
<p>13.) Cable glands must be process-connections considered suitable in accordance with IEC/EN 60079-26. 14.) Special conditions for safe use that are defined in the certificate of conformity and the installation manual must be obeyed. 15.) LX Plus console and all I.S. devices must be installed in accordance with its manufacturer's control drawing and Article 504 of the National Electrical Code (ANSI/NFPA 70) for installation in the United States, or Section 18 of the Canadian Electrical Code for installations in Canada. Other local codes, as applicable. 16.) LX Plus console must not be supplied from or contain, under normal or abnormal conditions, a source of potential with respect to earth in excess of 250V RMS; or 250V DC, um = 250V 17.) LX Plus console output current is limited by a resistor such that the output voltage-current plot is a straight line between open-circuit voltage and short-circuit current. 18.) Associated Apparatus is third party listed as providing intrinsically safe circuits for the application and have Voc or Vi not exceeding Vmax (or Uo not exceeding Ui), Isc or It not exceeding Imax (or Io not exceeding Ii), and the Po of the associated apparatus must be less than or equal to the Pmax or Pi of the intrinsically safe equipment as shown below</p>	<p>DESCRIPTIVE SYSTEM DOCUMENT - MogLink LX Plus</p> <p>NOTES:</p> <ol style="list-style-type: none"> This document shows the intrinsically safe equipment and associated apparatus that together create an intrinsically safe system. The LX Plus console must be installed in an indoor, non-hazardous area in accordance with this document and the installation manual. Only one LX Plus console can be connected to any single intrinsically safe apparatus. Multiple power sources, additional consoles or other associated apparatus, cannot be connected to the same intrinsically safe apparatus. The LX Plus supports a maximum of 12 probes and 24 sensors. It allows mixing probes and sensors on a single I.S. channel by connecting them in parallel. When connecting I.S. devices to the I.S. barrier the console uses a points system to calculate the mix of probes and sensors that can be installed on each of the four (4) barrier positions. Each of the LX Plus console's four (4) barrier positions can have up to a maximum of 12 "points" of connected devices (where probes = 4 points and sensors = 1 point). One barrier position can hold a total of 12 points (3 Tank-Probes, or 12 Smart-Sensors or a mix of probes and sensors). The wiring used to connect I.S. devices to the console must not exceed a capacitance of 328 pF/feet or 100 pF/foot. The total combined cable used to connect I.S. devices to the LX Plus console must not exceed a total cable capacitance of 5.0µF. Recommended cable for field wiring is Belden 88770 or equivalent. Do not exceed an inductance of 0.565µH/feet or 0.2µH/foot for each cable. Do not exceed 200µH/Ohm of a cable's L/R ratio. The total cable length used to connect up to 12 probes and 24 sensors to all LX Plus Barrier positions cannot exceed 2438 meters or 8,000 feet with each position wiring not exceeding 610 meters or 2,000 feet. The barrier ground must be connected directly to the ground bus of the main electrical panel. Use a minimum 4.0 mm² / 10 AWG conductor. Ground connections must be in accordance with IEC/EN 60079-14. The associated apparatus must be connected to a suitable ground electrode per the National Electrical Code (ANSI/NFPA 70), the Canadian Electrical Code, or other local installation codes as applicable. The resistance of the ground path must be less than 1 ohm. Field wiring connections must be made in a weatherproof junction box. Wires and wire nuts must be enclosed in a 3M™ Scotchcast™ Electrical Insulating Resin seal pack assembly (3570G-N). A risk assessment as to the susceptibility of the installation to lightning or other electrical surges must be made. Mitigations must be in accordance with IEC/EN 60079-25. Installers must know the requirements of intrinsically safe devices, comply with all national and local codes and must obey the instructions in the installation manual. The installer must decide if a simple apparatus used with this system complies and conforms to the requirements as follows: <ol style="list-style-type: none"> The simple apparatus must be constructed of passive components only (switches, junction boxes and resistors, etc.) The simple apparatus must be constructed without any sources of stored energy (batteries, capacitors and inductors). The simple apparatus must not be constructed with sources of generated energy that can produce greater than 1.5V and 25mW or have energy sources that can increase the voltage. A simple apparatus with a metallic housing must be able to tolerate a test voltage to earth as defined in IEC/EN 60079-11. Simple apparatus constructions with non-metallic enclosures and enclosures of light metals must comply with IEC/EN 60079-0 sections 7, 8 and IEC/EN 60079-26, clause 4.3.3 Based on the available power within the system, simple apparatus that have electrical components that exceed 20 mm² in total surface area, may be assessed as having a T4 temperature code at the specified ambient temperature range of -40 deg. C to +60 deg. C. other types of simple apparatus must be assessed in accordance with IEC/EN 60079-11, section titled "simple apparatus". A simple apparatus must not contain any means of increasing the available voltage or current, for example DC to DC converters.
<p>13.) Cable glands must be process-connections considered suitable in accordance with IEC/EN 60079-26. 14.) Special conditions for safe use that are defined in the certificate of conformity and the installation manual must be obeyed. 15.) LX Plus console and all I.S. devices must be installed in accordance with its manufacturer's control drawing and Article 504 of the National Electrical Code (ANSI/NFPA 70) for installation in the United States, or Section 18 of the Canadian Electrical Code for installations in Canada. Other local codes, as applicable. 16.) LX Plus console must not be supplied from or contain, under normal or abnormal conditions, a source of potential with respect to earth in excess of 250V RMS; or 250V DC, um = 250V 17.) LX Plus console output current is limited by a resistor such that the output voltage-current plot is a straight line between open-circuit voltage and short-circuit current. 18.) Associated Apparatus is third party listed as providing intrinsically safe circuits for the application and have Voc or Vi not exceeding Vmax (or Uo not exceeding Ui), Isc or It not exceeding Imax (or Io not exceeding Ii), and the Po of the associated apparatus must be less than or equal to the Pmax or Pi of the intrinsically safe equipment as shown below</p>	<p>DESCRIPTIVE SYSTEM DOCUMENT - MogLink LX Plus</p> <p>NOTES:</p> <ol style="list-style-type: none"> This document shows the intrinsically safe equipment and associated apparatus that together create an intrinsically safe system. The LX Plus console must be installed in an indoor, non-hazardous area in accordance with this document and the installation manual. Only one LX Plus console can be connected to any single intrinsically safe apparatus. Multiple power sources, additional consoles or other associated apparatus, cannot be connected to the same intrinsically safe apparatus. The LX Plus supports a maximum of 12 probes and 24 sensors. It allows mixing probes and sensors on a single I.S. channel by connecting them in parallel. When connecting I.S. devices to the I.S. barrier the console uses a points system to calculate the mix of probes and sensors that can be installed on each of the four (4) barrier positions. Each of the LX Plus console's four (4) barrier positions can have up to a maximum of 12 "points" of connected devices (where probes = 4 points and sensors = 1 point). One barrier position can hold a total of 12 points (3 Tank-Probes, or 12 Smart-Sensors or a mix of probes and sensors). The wiring used to connect I.S. devices to the console must not exceed a capacitance of 328 pF/feet or 100 pF/foot. The total combined cable used to connect I.S. devices to the LX Plus console must not exceed a total cable capacitance of 5.0µF. Recommended cable for field wiring is Belden 88770 or equivalent. Do not exceed an inductance of 0.565µH/feet or 0.2µH/foot for each cable. Do not exceed 200µH/Ohm of a cable's L/R ratio. The total cable length used to connect up to 12 probes and 24 sensors to all LX Plus Barrier positions cannot exceed 2438 meters or 8,000 feet with each position wiring not exceeding 610 meters or 2,000 feet. The barrier ground must be connected directly to the ground bus of the main electrical panel. Use a minimum 4.0 mm² / 10 AWG conductor. Ground connections must be in accordance with IEC/EN 60079-14. The associated apparatus must be connected to a suitable ground electrode per the National Electrical Code (ANSI/NFPA 70), the Canadian Electrical Code, or other local installation codes as applicable. The resistance of the ground path must be less than 1 ohm. Field wiring connections must be made in a weatherproof junction box. Wires and wire nuts must be enclosed in a 3M™ Scotchcast™ Electrical Insulating Resin seal pack assembly (3570G-N). A risk assessment as to the susceptibility of the installation to lightning or other electrical surges must be made. Mitigations must be in accordance with IEC/EN 60079-25. Installers must know the requirements of intrinsically safe devices, comply with all national and local codes and must obey the instructions in the installation manual. The installer must decide if a simple apparatus used with this system complies and conforms to the requirements as follows: <ol style="list-style-type: none"> The simple apparatus must be constructed of passive components only (switches, junction boxes and resistors, etc.) The simple apparatus must be constructed without any sources of stored energy (batteries, capacitors and inductors). The simple apparatus must not be constructed with sources of generated energy that can produce greater than 1.5V and 25mW or have energy sources that can increase the voltage. A simple apparatus with a metallic housing must be able to tolerate a test voltage to earth as defined in IEC/EN 60079-11. Simple apparatus constructions with non-metallic enclosures and enclosures of light metals must comply with IEC/EN 60079-0 sections 7, 8 and IEC/EN 60079-26, clause 4.3.3 Based on the available power within the system, simple apparatus that have electrical components that exceed 20 mm² in total surface area, may be assessed as having a T4 temperature code at the specified ambient temperature range of -40 deg. C to +60 deg. C. other types of simple apparatus must be assessed in accordance with IEC/EN 60079-11, section titled "simple apparatus". A simple apparatus must not contain any means of increasing the available voltage or current, for example DC to DC converters.

	
TITLE:	DESCRIPTIVE SYSTEM DOCUMENT
PART NO. Multiple	REV 0
DRAWING NO. 4130-LX Plus	SHEET 2 OF 3

D	1	2	3	4	5	6	7	8	B	C	A
	DESCRIPTIVE SYSTEM DOCUMENT - MagLink LX Plus										
	19.) Reference the following device certifications for applicable standards:										
[E-a] (a)	IECEN 60079-0	Electrical Apparatus for Potentially Explosive Atmospheres-part 0:									
	IECEN 60079-11	General Requirements									
	IECEN 60079-25	Electrical Apparatus for Potentially Explosive Atmospheres-part 11:									
	IECEN 60079-26	Electrical Apparatus for Potentially Explosive Atmospheres-part 25:									
	IECEN 60079-28	Electrical Apparatus for Potentially Explosive Gas Atmospheres-part 26:									
		Intrinsically Safe Systems									
		Electrical Apparatus for Explosive Gas Atmospheres - Part 26:									
		Construction, Test and Marking of Group II Zone 0 Electrical Apparatus									
	20.) The MagLink LX Plus has been designed to work safely with 9248 probes of various lengths and Smart Sensors with the following Type Designations:										
ISI without Sensor	Model 20-0348-ISI	ISI followed by NO, NC or DF									
ISI with Single Brass Float Assembly	Model 30-0230-S	Model 30-0230-S									
ISI with Single Plastic Float Assembly	Model 30-0231	Model 30-0231 followed by -1 or -S									
ISI with Dual Float with or without Hydrocarbon Sensor	Model 30-0232	Model 30-0232 followed by -D-XXX or -DH-XXX									
ISI with Interstitial Hydrocarbon Sensor	Model 30-0233	Model 30-0233 followed by -H or -HW									
ISI with Liquid Hydrocarbon Polymer	Model 30-0234	Model 30-0234 followed by -H-XX or -HW-XX									
ISI with Vapor Sensor with or without Water Detection	Model 30-0235	Model 30-0235 followed by -V or -VV									
ISI Simple Apparatus - connected to SiteSentinel NANO only through 20-0349-ISI		Model 30-0235 followed by -V or -VV									
	All suffixes denoted as XX or XXX indicate length of sensors.										
	21.) ENTITY PARAMETERS of devices listed above:										
Entity Parameters for the Associated Apparatus, MagLink LX Plus:											
V MAX (or UI) >= Voc or Vt (or Uo) = 14.85V											
I max (or I) >= Isc or It (or Io) = 305mA											
P max Pt >= Po = 974mW											
Cl = Cable <= Ca (or Co) = 3 or 5 uF											
L = Lcable <= La (or Lo) = 1.52mH or 600 uH											
Entity Parameters - 9248 Probe - Class I:											
(Vmax), Ua = 14.9V											
Cl = 0uF											
For Pt <= 1.3W											
For Pt <= 1.2W											
For Pt <= 1.0W											
(Vmax), Ua = 14.9V											
Cl = 0uF											
For Pt <= 1.0W											
For Pt <= 1.0W											
For Pt <= 1.0W											
Entity Parameters - 20-0349-ISI - ISI Standalone - Class I:											
(Vmax), Ua = 14.9V											
Cl = 0uF											
For Pt <= 1.0W											
For Pt <= 1.0W											
For Pt <= 1.0W											
Vt, Uo = 14.9V											
Ca, Co = 2uF											
Po = 0.55W											

Appendix D LX Plus Field Wiring Diagram

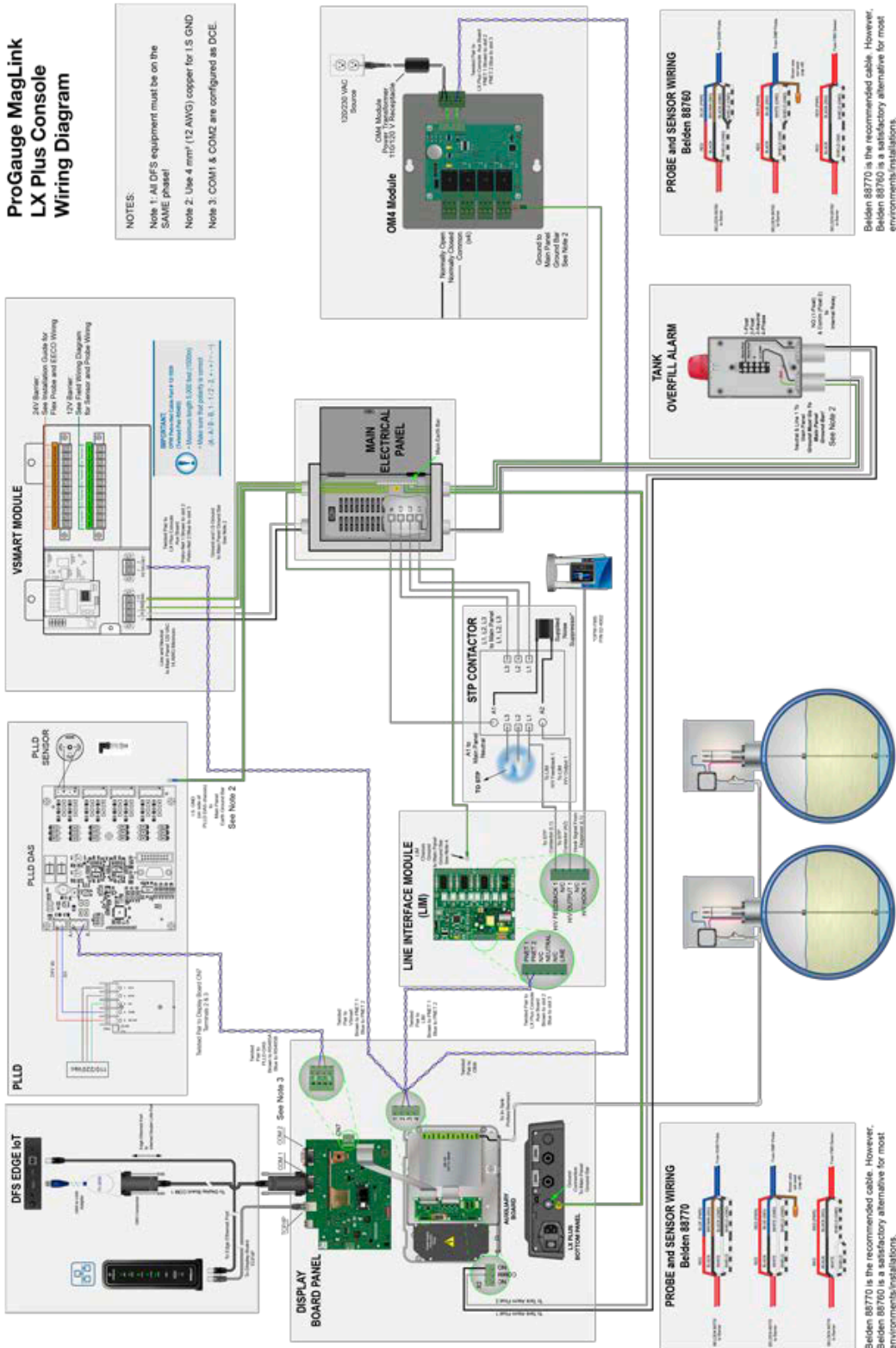

Revisions - M2050-PLUS

Revision #	Approve	Effective	Key Changes
0	ECO-2006	3/14/2022	Initial Release
1	ECO-2035	6/1/2022	Add Descriptive System Document
2	ECO-2045	7/28/2022	Add power shutdown instruction/note/warning panel. Updated SN label, add UL warning panels, correct # smart sensors on barrier from 24 to 48, add DMP Probe specs, add DMP Density Float, add Wiring Diagram.
2.1	DB	10/6/2022	Correction: Console Components > Front Panel, re-numbered to match photo annotation.
2.2	DB	10/31/2022	Add wiring diagram r1
3	DB	11/18/2022	Add peripheral devices; LIM, OM4, Tank Alert, VSmart. Update Field Wiring Diagram. Add Field Wiring with ProGauge components.
3.1	DB	3/3/2023	Update DMP wiring images, update functional test for sensor 30-0234-HW-XX
4	DB	8/4/2023	Add PLLD and PLLD DAS. Add spec table for relays.
5	DB/NA/WP	6/17/24	Security Best Practices, VSmart probe capacity
6	DB	4/20/2026	Added new PLLD sensor and updated OM4 wiring.



NOTE: *It is possible that older software versions might not support all features*

Installation

ProGauge MagLink LX Plus® Console

M2050-PLUS